



Anti shock air valve for high-rise buildings and pumping stations Mod. FOX 3F - AS - HR

The CSA air valve Mod. FOX 3F-AS-HR will ensure the proper operation of the system allowing the release of air pockets during working conditions, the entrance of large volumes of air during draining operations and pipeline bursts and the air discharge with controlled speed, to prevent water hammer.



We can refer to hydraulic transients meaning a temporary flow and pressure condition occurring in a hydraulic system between an initial steady-state condition and a final steady-state condition. If changes occur rapidly following the operation of a flow-control device (like a valve closure or pump start), the compressibility of the liquid and the elasticity of the pipeline cause a transient pressure wave propagating along the system. The variation can be either positive leading to excessive pressure and consequently damages, bursts or negative, causing pipe collapse and deformation.

In case of risers in general and for high-rise buildings in particular air valves need to be installed for the removal of air pockets, and water hammer for such applications is normally related to their fast closure in case of rapid filling and pump start up.

The anti-shock CSA air valves FOX 3F-AS-HR, a special version of the existing air valves range, has been designed to ensure the proper operation on the system any circumstances avoiding the sudden impact between the water surface and the float with consequent slow closing.

This model will also ensure the entrance of large volumes of air during pipe filling/draining and the air release during working conditions.

Technical features and benefits

- Body in ductile cast iron, PN 40 bar rated, provided with internal ribs for consistent and accurate guiding of the mobile block.
- Drainage valve produced by CSA, for chamber control and pressure relief during maintenance.
- Mobile block composed of a cylindrical float and upper disk in solid polypropylene, joined together by the CSA air release system in AISI 316 (pat. Pending).
- Nozzle and gasket holder, part of CSA air release system, entirely made in AISI 316 and designed with gasket compression control to prevent aging process and consequent leakage during working conditions.
- Anti water hammer system (also called AS function), never in contact with water, obtained by a spring and shaft in stainless steel, disk with adjustable sonic nozzles for air flow control.
- Threaded outlet elbow to avoid spray effect, conveying spurts coming from the closure away from the valve. This feature will also allow the proper operation in case of flood, without the risk of contaminated water entering the pipeline.
- The air valve is fitted with a Y strainer to prevent debris, solids from reaching the upper part where the air release system and seat is located causing possible malfunctioning.

Applications

- Pipeline risers.
- High-rise buildings.
- Irrigation and treated water pumping stations.

Operating principle

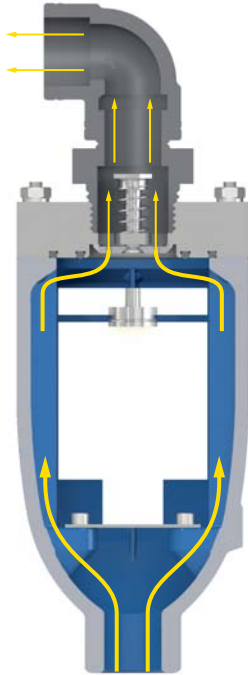

Controlled air discharge

During the pipe filling it is necessary to avoid rapid closures, responsible of water hammer effects. The FOX-3F-AS-HR, thanks to the anti-shock feature, will control the air outflow thus reducing the velocity of the approaching water column. The risk of overpressure will therefore be minimized.

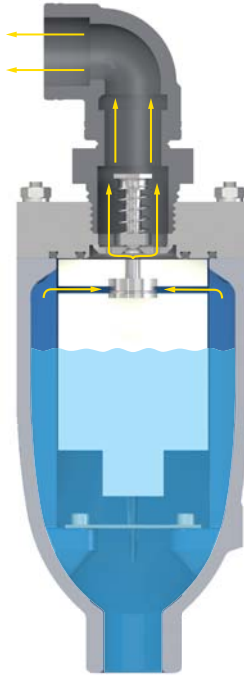

Air release during working conditions

During operation the air produced by the pipeline is accumulated in the upper part of the air valve. Little by little it is compressed and the pressure arrives at water pressure, therefore its volume increases pushing the water level downwards allowing the air release through the nozzle.

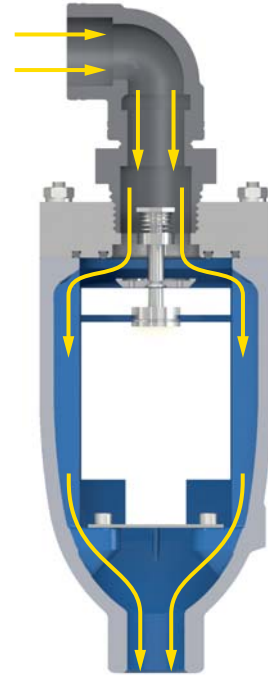

Entrance of large volumes of air

During pipeline draining, or pipe bursts, it is necessary to bring in as much air as the quantity of outflowing water to avoid negative pressure and serious damages of the pipeline, and to the entire system.

Installation

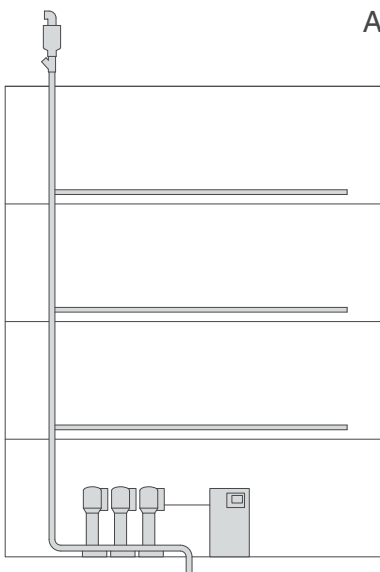

A

Some example of applications are depicted in the picture A and B. The first showing the installation on a vertical riser typical of a residential building, sky scraper, plants.

On the second image the air valve is located before the check valve of a pump to allow for the controlled air discharge during pump start up and air release in working conditions. We strongly advise to check and guarantee a minimum working pressure in order to avoid leakage, that can happen especially with high rise applications in dynamic conditions.

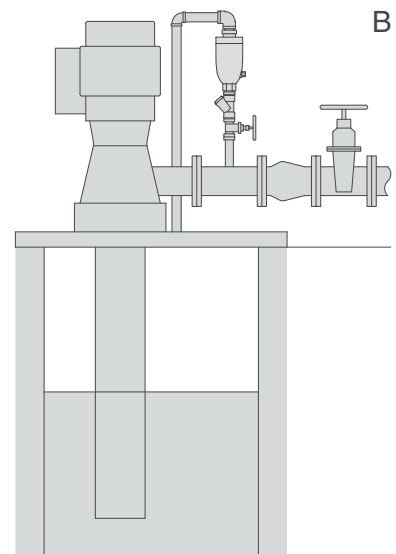

B

Technical data

Air valve selection chart

Range of application of the air valve as a function of pipeline internal diameter and fluid flow velocity expressed in m/s.

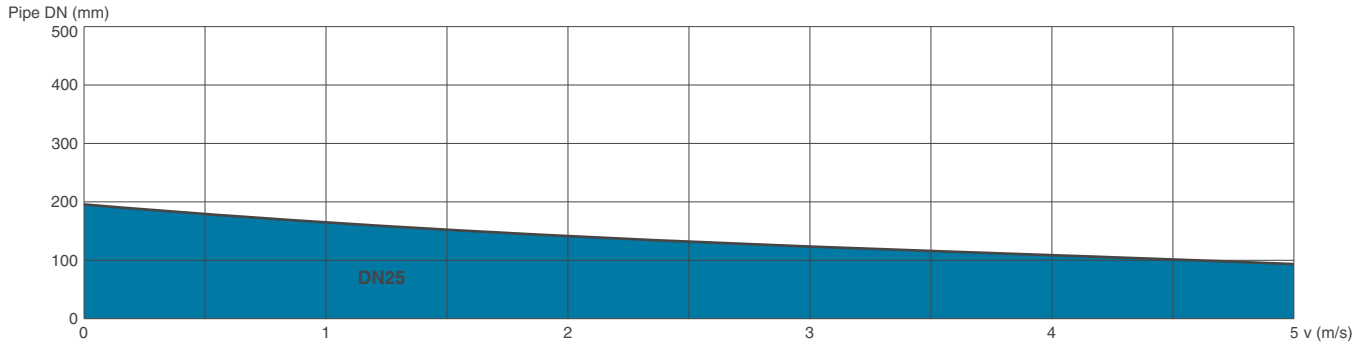

Air flow performance charts

AIR ENTRANCE DURING PIPE DRAINING

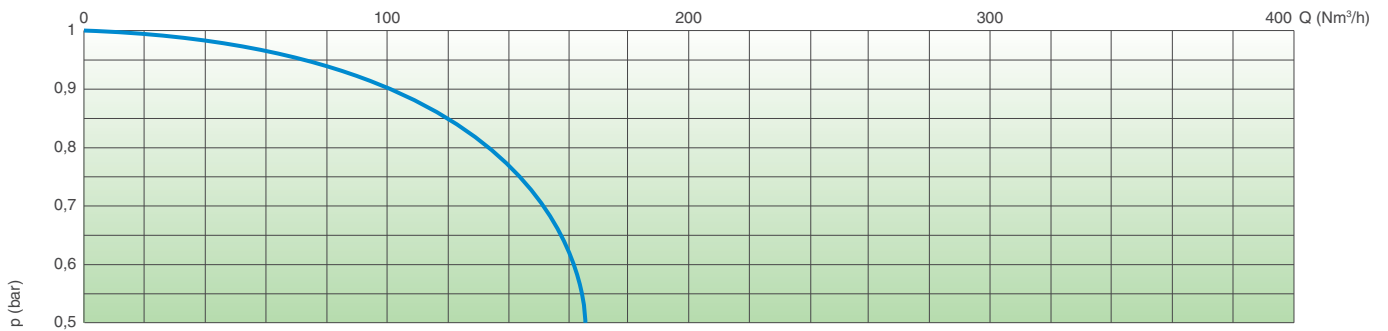

Working conditions

Treated water max. 60°C.
Max. pressure 40 bar.
Min. pressure 0,1 bar.

Standard

Designed in compliance with EN-1074/4 and AWWA C-512.
Epoxy painting applied through fluidized bed technology blue RAL 5005.
Changes and variations on painting available on request.

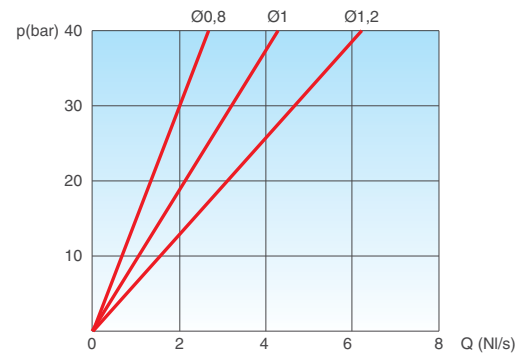

AIR RELEASE DURING WORKING CONDITIONS

Nozzle choice

Nozzle diameter in mm according to the size of the air valve and the PN.

PN 10	PN 16	PN 25	PN 40
1,2	1,2	1	0,8

Weights and dimensions

A inch	B inch	C mm	D mm	E mm	Weight Kg
1"	1"	395	105	70	3,2

DN 2" and larger size available on request.

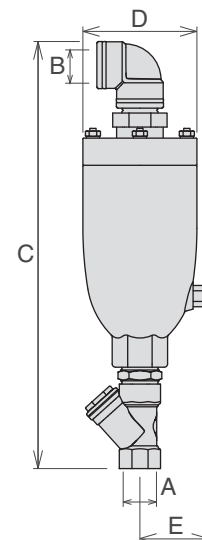

Technical details

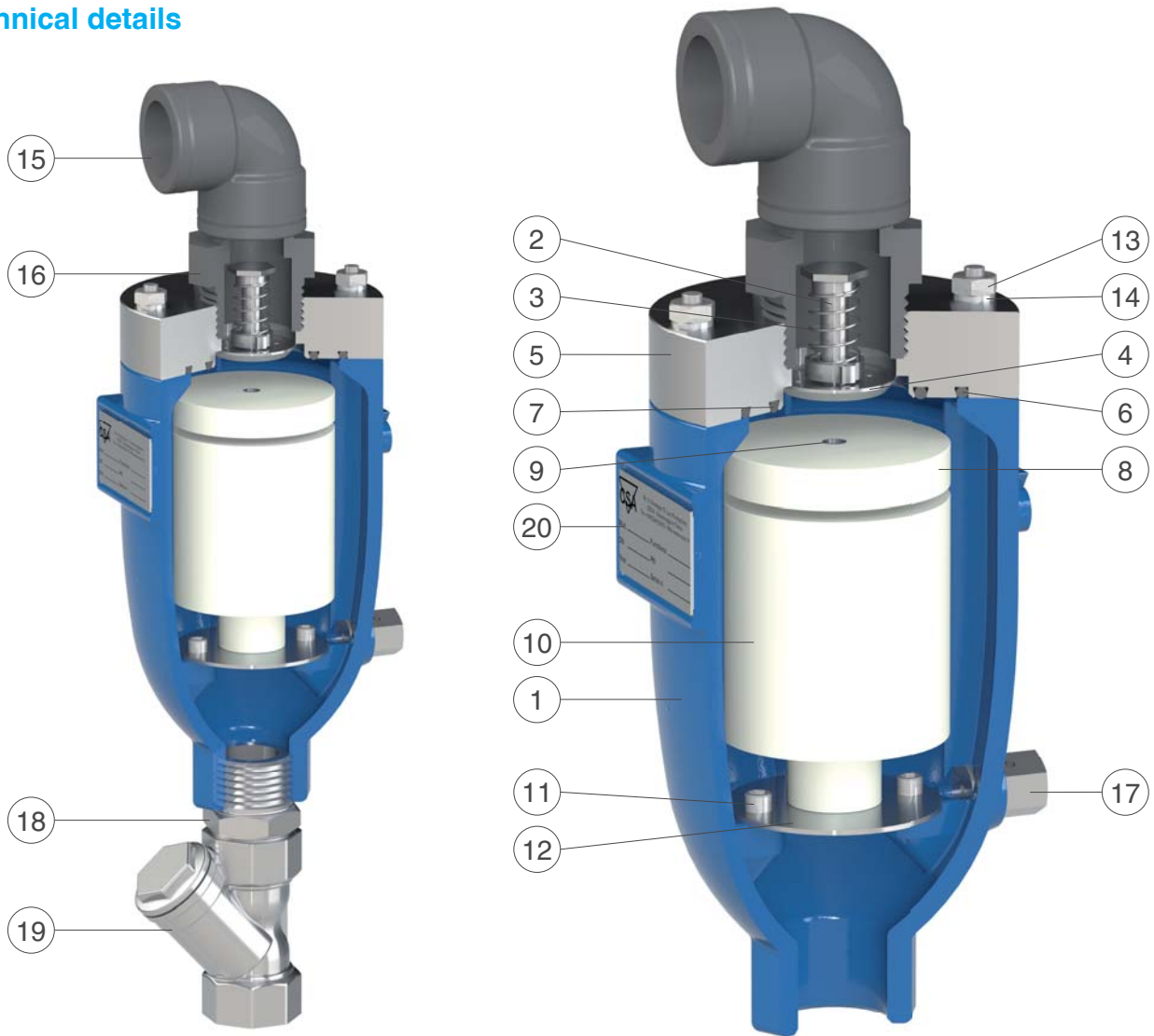

		Standard material	Optional
1	Body	ductile cast iron GJS 500-7 or GJS 450-10	
2	AS shaft	stainless steel AISI 303	
3	AS spring	stainless steel AISI 302	
4	AS flat	stainless steel AISI 303	
5	HR seat	stainless steel AISI 303	
6	O-ring	NBR	EPDM/Viton/silicone
7	O-ring	NBR	EPDM/Viton/silicone
8	Upper flat	polypropylene	
9	Nozzle subset	stainless steel AISI 316	
10	Float	polypropylene	
11	Screws	stainless steel AISI 304	stainless steel AISI 316
12	Deflector	stainless steel AISI 304	stainless steel AISI 316
13	Nuts	stainless steel AISI 304	stainless steel AISI 316
14	Washer	stainless steel AISI 304	stainless steel AISI 316
15	Threaded elbow 1"	polypropylene	stainless steel AISI 316
16	Fitting 1 1/4" - 1"	polypropylene	stainless steel AISI 316
17	Drain valve	stainless steel AISI 303	stainless steel AISI 316
18	Fitting 1"	brass	stainless steel AISI 316
19	Filter 1"	bronze	brass/stain. steel AISI 316
20	Tag	stainless steel	

The list of materials and components is subject to changes without notice.