



MC608 Converter

Installation Manual

Vers. 6.0 and subsequent

PLEASE READ THESE INSTRUCTIONS
AND KEEP IN A SAFE PLACE



TD210-1-ENG







IMPORTANT WARNING

IT IS VERY IMPORTANT THAT ALL THE STAFF WORKING WITH THE EQUIPMENT HAVE READ AND FULLY UNDERSTOOD THE INSTRUCTIONS AND INFORMATION PROVIDED IN THIS MANUAL AND FOLLOW AND APPLY THEM BEFORE USING IT. THE MANUFACTURER IS NOT LIABLE FOR ANY CONSEQUENCES RESULTING FROM MISUSE BY THE OPERATOR.

The operator shall bear responsibility for the suitability of the device for the specific purpose:

Improper installation and operation of the devices (systems) will cause warranty to be void

- The manufacturer will not be liable for any kind of damage resulting from the use of its products, including, but not limited to those deemed direct, indirect, incidental, punitive and consequential. The installation, connection, commissioning and maintenance must be performed by staff specifically qualified and authorized for that purpose.
- The installation personnel must ensure that the measuring system is correctly connected in accordance with the wiring diagram.

For applications that require high working pressures or substances that may be hazardous to the people, the environment, equipment or anything else if a pipe breakage occurs, Euromag International recommends, that before installing the sensor the operator takes the appropriate precautions such as precautions such as the correct location, protection or the mounting of a guard or safety valve.

The device contains live electrical components, thus the installation, monitoring and maintenance must be carried out by qualified and experienced staff fully aware of all the necessary precautions. Before opening any inner part, please disconnect the power supply.

The flow meter consists of metal and plastic parts, all of which must be in compliance with local rules and requirements concerning waste disposal.

PLEASE READ AND KEEP THESE INSTRUCTIONS IN A SAFE PLACE

This manual can be downloaded from the internet www.euromag.com visiting the download area.

To ensure a proper and safe installation we strongly recommend thoroughly reading this operation manual.



CAUTION!

RISK OF ELECTRIC SHOCK!
ALL OPERATIONS MARKED WITH THIS SYMBOL SHOULD ONLY BE CARRIED OUT BY
QUALIFIED TECHNICIANS.



CAUTION!

CRUCIAL INFORMATION AND INSTRUCTIONS TO BE APPLIED.
PLEASE REFER TO THE ANNEXED DOCUMENTS .

NOTE

INFORMATION AND INSTRUCTION
REQUIRING SPECIAL ATTENTION.

CE/EMC/Norme



The manual that describes this flowmeter conforms to the following safety rules:

- Directives EN 61326-1:2006, EN 55011:2009 + / A12010, EN 6100-3 (2/3), EN 6100-4 (2/3/4/5/6/8/11).
- Directive EN61010-1 (pending)
- Directive EN 60529 (pending)
- It is in class A.

In addition, it is essential to read the manual start-up that accompanies the flow meter and which is contained in the package.

Manufacturer's design and safety statement

- Responsibility for the choice of lining and electrode materials in regards to abrasion and corrosion resistance lies with the purchaser. The effect of any change in fluid process during the operation of the device must be taken into account. Incorrect selection of lining and/or electrode could lead to a failure of the device.
- While designing the device stresses and loads possibly caused by earthquakes, traffic, strong winds and fire damage were not taken into account.
- Do not install the device so that it acts as a focus for pipeline stresses. In the configuration of the device please take into account any external loads.
- During operation do not exceed the pressure and/or temperature ratings indicated on the nameplate or in this Operating Manual.

Battery Operation:

- Lithium batteries are primary power sources with high energy content. They are designed to meet the highest possible safety standards. They may, however, pose a potential hazard if they are misused either electrically or mechanically which may cause the generation of excessive heat and possible breakage of the cell.

Thus the following basic precautions should be observed when handling and using lithium batteries:

- Do not short-circuit, recharge, overcharge or connect with incorrect polarity
- Do not expose to temperature beyond the specified temperature range or incinerate the battery
- Do not crush, puncture or open cells or disassemble battery packs
- Do not weld or solder to the body of the battery, or the battery packs
- Do not expose contents to water

Lithium batteries are regulated under United Nations Model Regulations on Transport of Dangerous goods (UN document on transport of hazardous goods), UN ST/SGAC document. 10-1, 12th revised edition, 2001. The UN document No. 3091

Class 9 covers the lithium batteries packed with the equipment or inserted into it. The UN document No. 3090 Class 9 only covers the transport of the batteries themselves.

Thus the following basic precautions should be followed when transporting lithium batteries:

- Transport only in special packaging with special labels and transportation documents.
- Use caution in handling, transporting and packaging in order to prevent short circuiting of the batteries.
- The gross mass of the package is limited according to the type of transportation. In general, a gross mass of less than 5 kg is acceptable for all forms of transport
- The batteries comply with the requirements set out in "UN Manual of tests and criteria, Part III, subsection 38.3" for transport by air and with the provisions of the ADR regulations for the transport by truck/sea.



- Remove the battery from the transmitter before returning the flow meter to Euromag International for possible service or warranty claim.

SUMMARY

MANUFACTURER'S DESIGN AND SAFETY STATEMENT	5
BATTERY OPERATION	5
1. PRELIMINARY NOTES	10
2. GENERAL PRECAUTIONS	10
3. SENSOR INSTALLATION	12
3.1 IDENTIFICATION NAMEPLATE	12
3.2 BIDIRECTIONAL READING	12
3.3 INSTALLATION INSTRUCTIONS	13
3.3.1 POSITIONING IN RELATION TO THE PLANT	13
3.3.2 POSITIONING IN RELATION TO THE FLOW	14
3.3.3 IMPORTANT INSTRUCTIONS ON MOUNTING	15
3.3.4 CHARTS OF MAXIMUM ALLOWABLE TORQUES	15
3.3.5 IMPORTANT GUIDELINES FOR CORRECT INSTALLATION	17
3.3.6 IMPORTANT GENERAL INFORMATION FOR A PROPER INSTALLATION	20
3.3.7 INSTALLATION EXAMPLE OF WAFER METER (MUT1000EL – MUT1100J)	21
4. POTENTIAL EQUALIZATION	22
5. NEGATIVE PRESSURE IN THE PIPE	24
6. INSTRUCTIONS FOR DIAMETER REDUCTION	24
7. INFORMATION CONCERNING THE MC608R CONVERTER	25
8. INSERTION METERS	26
8.1 INTRODUCTION	26
8.1.1 FEATURES AND BENEFITS	26

8.1.2 SYSTEM DIAGRAM	27
8.1.3 MECHANICAL INSTALLATION	27
8.2 INSTALLATION	28
8.2.1 MEAN AXIAL VELOCITY POINT (1/8 OF THE INTERNAL DIAMETER)	29
8.2.2 ALIGNMENT	29
8.2.3 PROGRAMMING	29
9. MC 608 CONVERTER	30
9.1 INSTALLATION	30
9.1.1 IDENTIFICATION NAMEPLATE	30
9.1.2 COMPACT VERSION	30
9.1.3 REMOTE VERSION	31
9.1.4 ELECTRICAL CONNECTIONS	34
9.1.5 MODBUS RS485 OUTPUT	37
9.1.6 ELECTRICAL GROUNDING OF THE CONVERTER CASE	37
9.1.7 CONNECTION TO THE POWER SUPPLY	38
9.2 MC608 CONVERTER PROGRAMMING	38
9.2.1 PROGRAMMING	41
10. DESCRIPTION OF THE MENU	44
10.1 OPTIONS	44
10.1.1 TECHNICAL UNITS	44
10.1.2 MEASUREMENT FREQUENCY	45
10.1.3 DISPLAY	45
10.1.4 VIEW OPTIONS	46
10.1.5 FULL SCALE FLOW RATE	46

10.1.6 LANGUAGE	46
10.2 COUNTERS	46
10.3 PARAMETERS	47
10.3.1 KA SETUP	47
10.3.2 DIAMETER SETUP	47
10.3.3 FILTERS SETUP	48
10.3.4 ZERO FINDER	50
10.3.5 FLOW RATE ALARMS	50
10.3.6 EMPTY PIPE THRESHOLD	50
10.4 I/O	51
10.4.1 PULSE OUTPUT	51
10.4.2 FREQUENCY OUTPUT	52
10.4.3 PROGRAMMABLE OUTPUT	52
10.4.4 PROGRAMMABLE INPUT	53
10.4.5 BATCHING	53
10.4.6 PROGRAMMABLE OUT LOGIC	54
10.5 OTHERS	54
10.5.1 SYSTEM INFO	54
10.5.2 TIME/DATE	54
10.5.3 RESERVED	54
10.5.4 GRAPH	54
10.5.5 SIMULATION	54
10.5.6 COMMUNICATIONS	54
10.5.7 DATA CONNECTION (RS485/IRCOMM)	54

10.6 MEMORY	55
10.6.1 LOAD USER COPY	55
10.6.2 SAVE USER COPY	55
10.6.3 FACTORY SETTINGS	55
10.6.4 DATALOGGER	55
10.6.5 PASSWORD SETUP	57
11. TECHNICAL DATA	58
11.1 GENERAL FEATURES	58
11.2 CERTIFICATES AND APPROVALS	59
11.4 ACCURACY	60
12. RETURN OF THE FLOW METER FOR ANY CHEK OR REPAIR	61
13. APPENDIX - TROUBLESHOOTING	62
REPAIR APPLICATION FORM	65
NOTE	66

1. PRELIMINARY NOTES

The main parts composing the electromagnetic flow meter consists of:

- A. The sensor – is installed in the pipes using flanges or threaded attachments or clamp attachments
- B. The converter – may be installed on the sensor (in compact version), or nearby (in remote version) connected via two cables.

Electromagnetic flow meters have many important advantages with respect to relevant mechanical counterparts, including among the others: outstanding long term stability, maximum process reliability, no need for maintenance. Consequently, these sensors can deliver accurate and reliable measurements for many years.

Please see the paragraphs below for more detailed instructions on correct installation.

NOTE

- ELECTROMAGNETIC FLOW METERS ARE SPECIFICALLY DESIGNED TO WORK UNDER FEW BASIC CONDITIONS:
1. LIQUID MUST BE CONDUCTIVE
 2. THE PIPE MUST ALWAYS BE COMPLETELY FILLED
 3. INLET AND OUTLET DISTANCES MUST BE THOSE RECOMMENDED

2. GENERAL PRECAUTIONS

The proper lifting method is shown in Figure fig_2_1, while it must be avoided that shown in Figure fig_2_2; to be noticed, do **NOT** raise the flow meter gripping the converter, but always holding it on the sides.



fig_2_1



fig_2_2

Moreover:

DO NOT move the flow meter with the lifting device without the original packaging or without the help of an appropriate support, ensuring the required stability.



fig_2_3

Compact version



fig_2_4

IP67 (Nema 4X)

- possibility of immersion 1 meter;
- maximum immersion time 12 hours. Separate version

Separate version



fig_2_5

IP67 Electronics (Nema 4x)

IP68 Sensor (Nema 4x)

- possibility of continuous immersion in 1.5 metres water column.

NOTE

THE JUNCTION BOX ON THE SENSOR IS DESIGNED TO BE IP68 PROTECTED ONLY WHEN PROPERLY CLOSED AND FULL TIGHTENED. THE MANUFACTURER ACCEPTS NO LIABILITY FOR IMPROPER CLOSING CARRIED OUT BY THIRD PARTIES.

3. INSTALLATION OF THE SENSOR

3.1 IDENTIFYING DATA PLATE

The plate located on the sensor carries the following data:

- MODEL:
- PART No.: the part number identifying the device (identification number for tracing the identity)
- DN: nominal diameter [inches or mm]
- PN nominal pressure [bar/s]
- Temp.: maximum process temperature
- IP: international degree of protection
- ELECTRODES: composition of the material making up the electrodes
- LINING: internal lining material
- KA: calibration coefficients
- ART.: other special guidelines

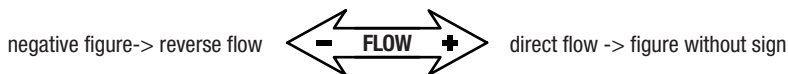
MODEL	MUT 2200EL
PART N°	WAC 276
DN	8" PN 16
Temp.	80° IP 68
ELECTRODES	H-C
LINING	PTFE
KA	+2.6428
ITEM	
STD Flange A150 Made in Italy	

fig_3_1

3.2 BIDIRECTIONAL READING

In the sensor, if the liquid flows:

- in the same direction of the arrow (enter by – and exit by +), the flow is positive and the display will show a reading with no sign;
- in the opposite direction to that indicated by the arrow (enter by + and exit by –), the flow is negative and the display will show a reading with negative sign;



INSTALLATION INSTRUCTIONS

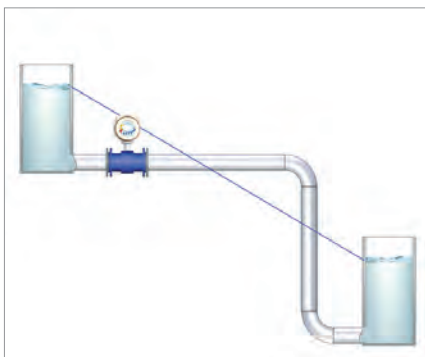
IMPORTANT NOTE

THE SENSOR MUST ALWAYS BE COMPLETELY FULL WITH LIQUID!

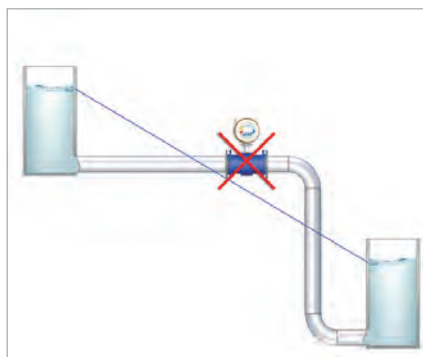
3.3.1 POSITIONING IN RELATION TO THE PLANT

For efficient working conditions, please carefully follow the instructions in figure 3_3_1.

The flow meter must remain below the hypothetical blue line (piezometric level line) which connects the two levels of fluid to be measured.



fig_331_1

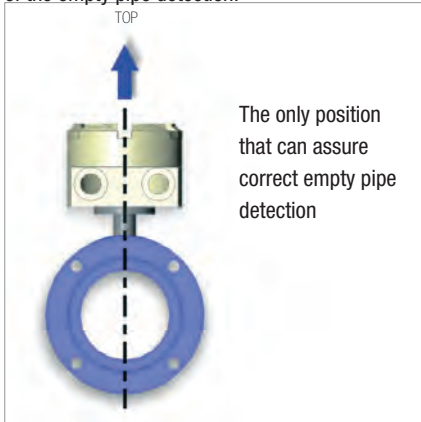


fig_331_2

Avoid placing the flow meter above the piezometric level line

3.3.2 POSITIONING IN RELATION TO THE FLOW

With installations on horizontal pipes, the converter (or the junction box in the separate version) must be placed upright to ensure the proper functioning of the empty pipe detection.



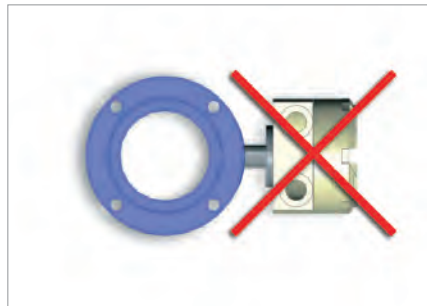
fig_332_1

In case of obstruction, follow the guidelines as explained in the figures below.



fig_332_2

Avoid following positions:

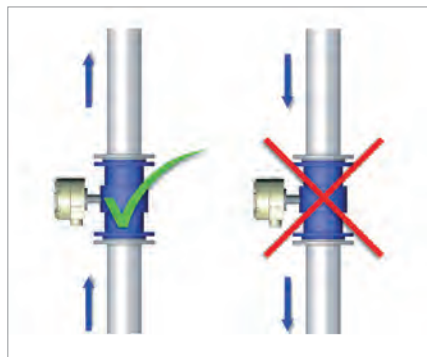


fig_332_3



fig_332_4

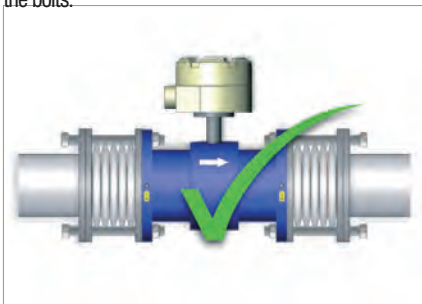
Recommended installation is on a vertical/inclined pipe with upward flow direction, to minimize the wear and deposits in the sensor. Avoid installation in vertical pipes with free outlet.



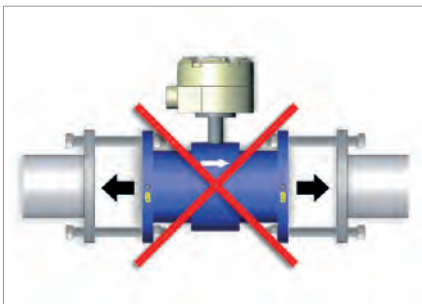
fig_332_5

3.3.3 IMPORTANT INSTRUCTIONS ON MOUNTING

Use elastic pipe fittings where there is not adequate distance between the sensor and the pipe. Do not attempt to bring the pipe to the sensor by tightening the bolts.

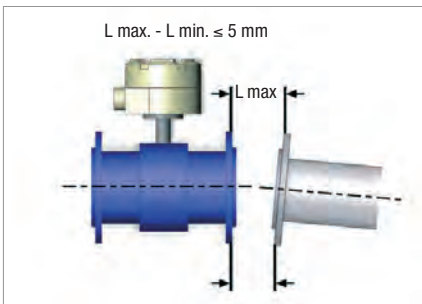


fig_333_1



fig_333_2

Max. allowable deviation of pipe flange faces is 0.5mm



fig_333_3

3.3.4 CHARTS OF MAXIMUM ALLOWABLE TIGHTENING TORQUES

Standard bolts must be well lubricated and tightened evenly around the gasket. If the bolts are tightened excessively, they may result in leaks or damage to the flow meter or to the pipe. Carefully follow any instructions provided by the graphics, carefully check the correct centring of the sensor before attaching the flanges and then proceed by following the steps below:

- Step 1. approx 50% of maximum tightening torque;
- Step 2. approx 80% of maximum tightening torque;
- Step 3 100% of the maximum tightening torque provided in the chart.

All values are theoretical and were calculated for optimum conditions and use with carbon steel flanges.



fig_334_1

PPBT+ MUT 1100J FIBREGLASS

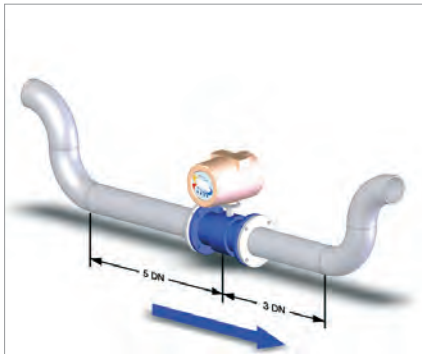
Sensor	Maximum operating pressure		Pipe flange - Flange - Class		Max. allowable tightening torques	
	[bar]	[psig]	flange	class	[Nm]	[ftlb]
DN 40	≤10	≤145	DN 40	PN 16/40	25	13
DN 50	≤10	≤145	DN 50	PN 16/40	35	19
DN 65	≤10	≤145	DN 65	PN 16/40	35	19
DN 80	≤10	≤145	DN 80	PN 16/40	35	19
DN 100	≤10	≤145	DN 100	PN 16/40	45	24
DN 125	≤10	≤145	DN 125	PN 16/40	65	35
DN 150	≤10	≤145	DN 150	PN 16/40	85	45
DN 200	≤10	≤145	DN 200	PN 16/40	100	53
1 1/2"	≤10	≤145	1 1/2"	150/300	25	13
2"	≤10	≤145	2"	150/300	35	19
2 1/2"	≤10	≤145	2 1/2"	150/300	35	19
3"	≤10	≤145	3"	150/300	35	19
4"	≤10	≤145	4"	150/300	45	24
5"	≤10	≤145	5"	150/300	65	35
6"	≤10	≤145	6"	150/300	85	45
8"	≤10	≤145	8"	150/300	100	53

3.3.5 IMPORTANT GUIDELINES FOR CORRECT INSTALLATION

For a correct working condition please follow the important guidelines shown in the following figures. Improper installation result in inaccurate measurement.

To achieve the most accurate flow measurement it is essential to have minimum straight lengths of the inlet and outlet pipes as shown (DN: sensor nominal diameter)

- For partially filled pipes or pipes with downward flow and free outlet, the flow meter should be located in a U-tube, respecting the upward and downward lengths between the curves.



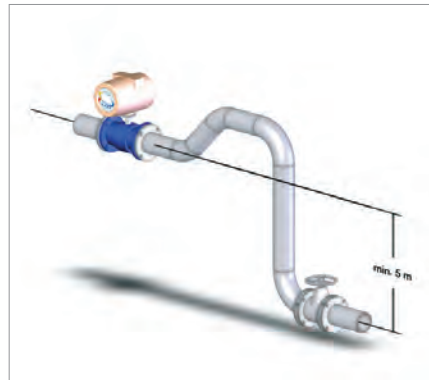
fig_335_1

- In the case of T-connection between two different tubes, please keep a 10DN distance upstream of the flow meter.



fig_335_2

- Keep 5 meters between the axis of the flow meter and those of the gate valve placed downstream.



fig_335_3

RECOMMENDED INSTALLATIONS (✓) AND THOSE TO BE AVOIDED (✗):

IMPORTANT NOTE

THE SENSOR MUST ALWAYS BE COMPLETELY FULL WITH LIQUID!

- In this installation the sensor is full with liquid



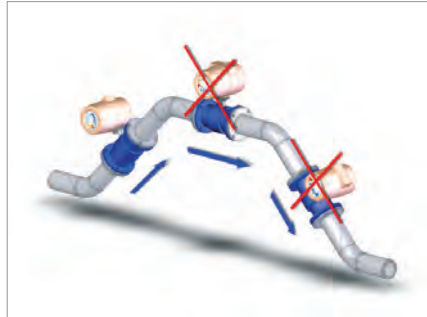
fig_335_4

- This installation DOES NOT guarantee a full pipe condition.



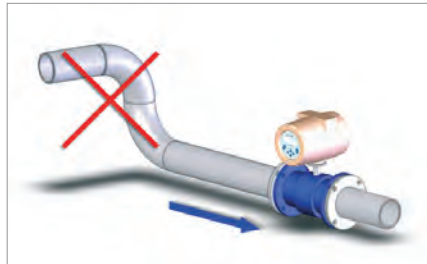
fig_335_5

- The position on the left is correct, the other two ARE NOT.



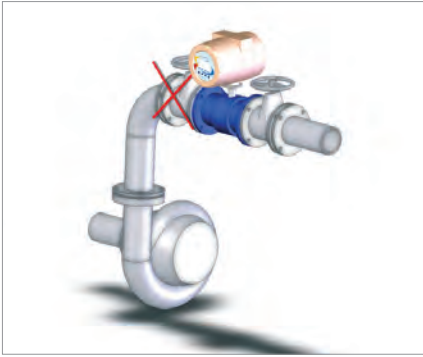
fig_335_6

- DO NOT place the sensor close to any variation in the path of the flow.



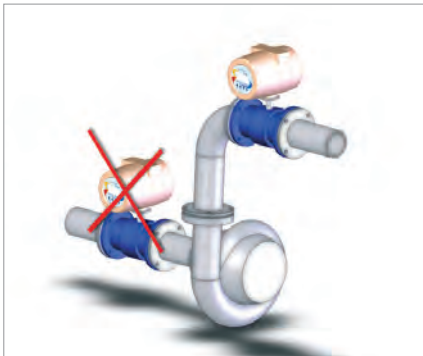
fig_335_7

- DO NOT place any gate valve directly connected upstream the sensor.



fig_335_8

- Always install the sensor downstream the pump and NEVER upstream to avoid vacuum.



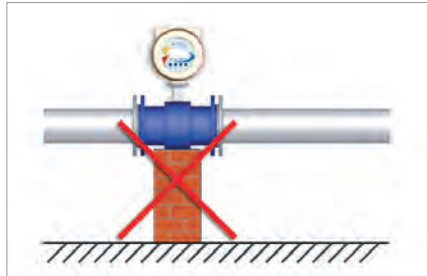
fig_335_9

- DO NOT install the sensor in vertical pipes with free outlet or at the highest point in the pipe system



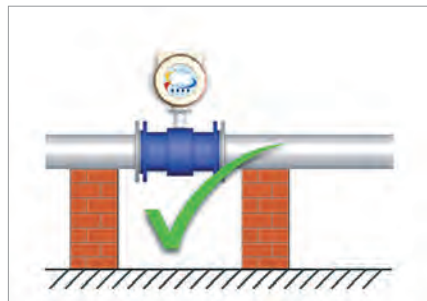
fig_335_10

- DO NOT use the sensor as a support for the tube.



fig_335_11

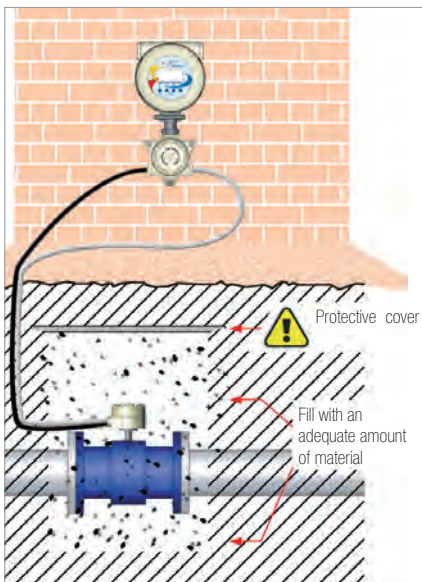
- The tube must act as a support for the flow meter.



fig_335_12

UNDERGROUND INSTALLATIONS

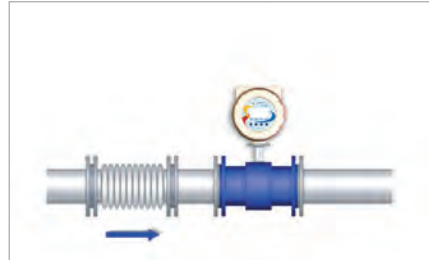
- The remote sensor is protected to IP68/NEMA 6P and can be positioned underground. We recommend the use of gravel for at least 300mm (12 inches) around the sensor. This provides certain drainage and prevents dirt from solidifying on the sensor, in addition it facilitates its location whenever new excavations are required. Before covering the gravel with earth, we suggest using electrical cable identification tape above the gravel itself. The remote sensor cable should pass through a conduit made of plastic and of minimum 50mm (2 inches).
- It is recommended the junction box made of steel in the case of underground installations.



fig_335_15

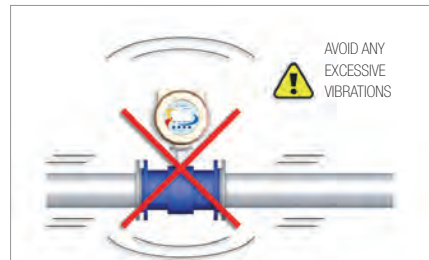
3.3.6 IMPORTANT GENERIC INDICATIONS FOR A CORRECT INSTALLATION

- Install a suitable anti-vibrational protection if any vibration arise.



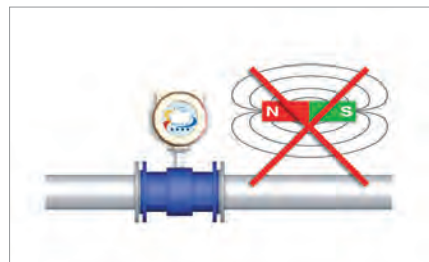
fig_336_1

- DO NOT expose the flow meter to vibrations and/or movement, which may affect its performance and duration.



fig_336_2

- AVOID exposing the flow meter to strong or nearby magnetic fields.



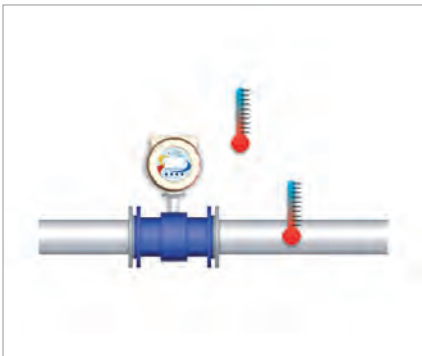
fig_336_3

- Protect the flow meter if exposed to direct sun radiations.



fig_336_5

- For a normal and efficient operation of the flow meter:
 - The ambient temperature must be limited within a range of $(-25 \div +60) ^\circ\text{C}$, $(-13 \div +140) ^\circ\text{F}$;
 - The temperature of the motherboard is available in the converter: Menu -> Other -> time / date
 - The temperature of the liquid should be limited within a range of $(-25 \div +80) ^\circ\text{C}$, $(-13 \div +176) ^\circ\text{F}$ for the compact version and $(-25 \div +200) ^\circ\text{C}$, $(-13 \div +392) ^\circ\text{F}$ for the remote version.



fig_336_6

IMPORTANT NOTE

NOTE FOR CONNECTION OF ATEX APPROVED FLOW METERS CABLING REQUIREMENTS IN POTENTIALLY EXPLOSIVE ATMOSPHERES (ATEX). LAY THE CABLES AS REQUIRED BY STANDARD EN 60079-14, IN PARTICULAR PROVIDING MECHANICAL PROTECTION, FOR EXAMPLE, RIGID OR FLEXIBLE CONDUIT PIPES, DUCTS OR SIMPLY CRANKCASES.

3.3.7 EXAMPLE INSTALLATION OF WAFER METERS (MUT1000EL - MUT1100J)



fig_337_1

4. POTENTIAL EQUALIZATION

- Liquid potential equalization or grounding is accomplished with the built-in grounding electrode (so called 3rd electrode). The 3rd electrode electrically bond the liquid to the device to provide a stable and accurate measurement.

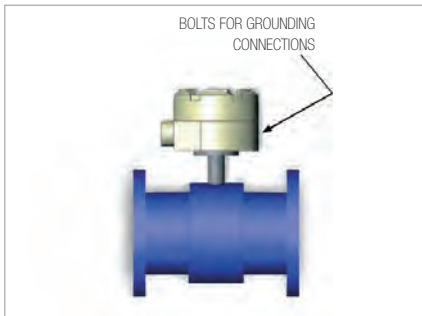
IMPORTANT NOTE

THE SENSOR MUST ALWAYS BE GROUNDED!
AN INCORRECT GROUNDING CONNECTION MAY LEAD
TO INCORRECT MEASUREMENTS

NOTE

THE FLOW METER IS EQUIPPED WITH A GROUNDING ELECTRODE (THIRD ELECTRODE). IN THE CASE OF PLASTIC OR LINED PIPES IT IS RECOMMEND THE USE OF GROUND RINGS.

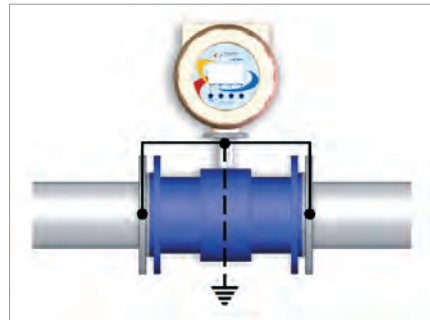
Separate version



fig_4_1

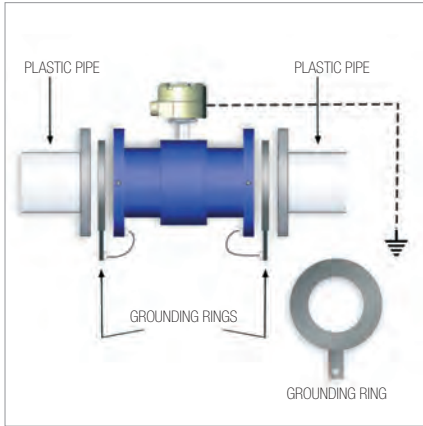
- The body of the sensor must be grounded using the ground/connections straps and/or grounding rings to protect the flow signal from electrical noise and/or from lightning. This ensures that any noise is transported through the body of the sensor thereby achieving a measurement area free from noise within the body of the sensor

Compact version



fig_4_2

- On plastic pipelines and lined metal pipes, OPTIONAL grounding rings can be used at both ends to ensure a good potential compensation. Grounding rings are not supplied as standard.

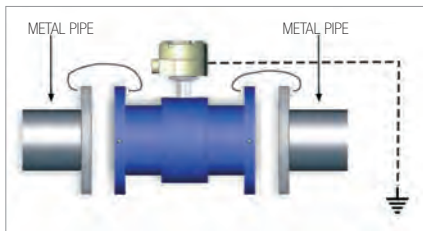


fig_4_3

NOTE

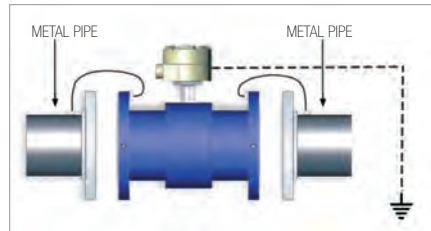
GROUNDING CABLE:
 MIN 2.5 MM²
 RECOMMENDED: 4 MM²
 GROUNDING SCREW: 5MM

Metal pipe



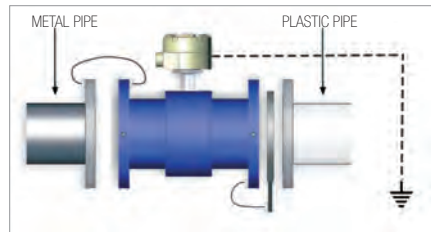
fig_4_4

Metal pipe with adapters



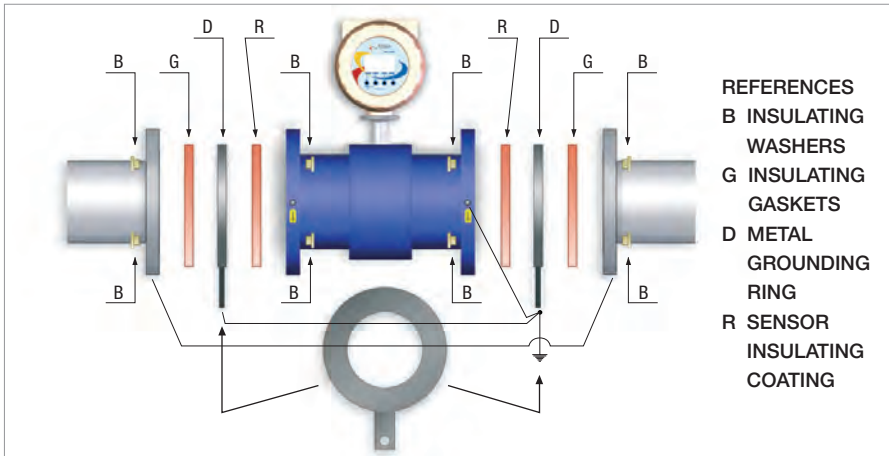
fig_4_5

Metal and plastic pipe



fig_4_6

- Particularly close attention must be paid when installing the product in the pipeline with cathodic protection. Isolate it from the pipeline by installing isolation bushings and washers on the bolts of the flange and connect a wire between the pipes, large enough to handle the cathodic current and the environmental effect. Use of the grounding rings on both ends. See fig_4_7 on the next page.



fig_4_7

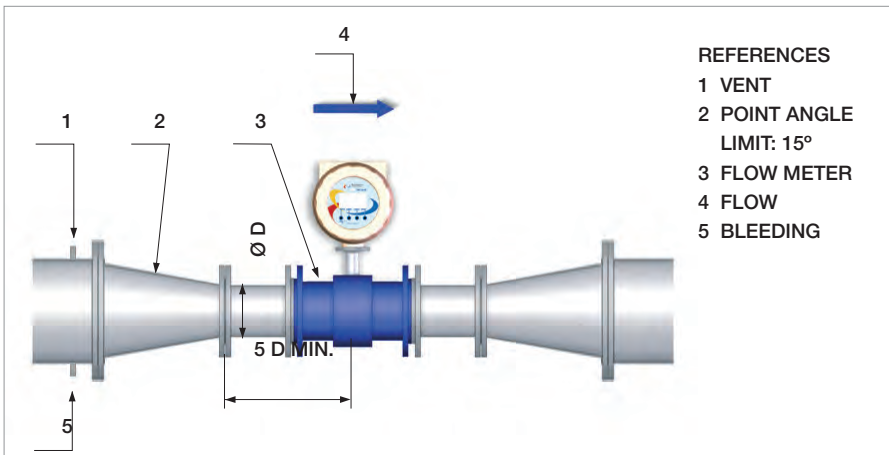
5. NEGATIVE PRESSURE IN THE PIPE

Avoid vacuum conditions in the pipe, these can damage the lining of the flow meter and move the electrodes from their correct position.

6. INSTRUCTIONS FOR DIAMETER REDUCTION

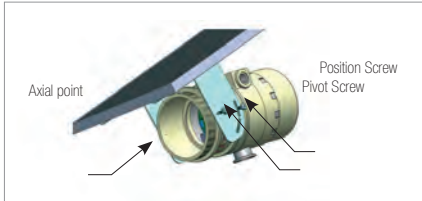
In the event of a reduction in the diameter, refer to the instructions given in the figure below.

UNI EN ISO 6817:1997



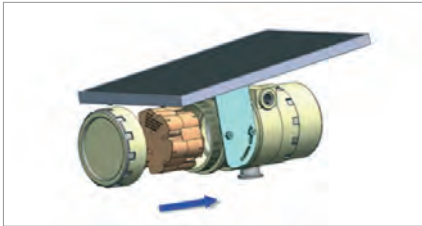
fig_6_1

7. INFORMATION CONCERNING THE MC608R CONVERTER



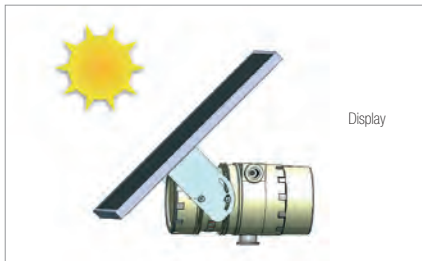
fig_7_1

- Connect the battery pack (blue cables).
- Insert the cartridge into the extension cylinder.
- Mount the aluminium rear box, and screw on in order to obtain an optimal sealing through the O-ring.

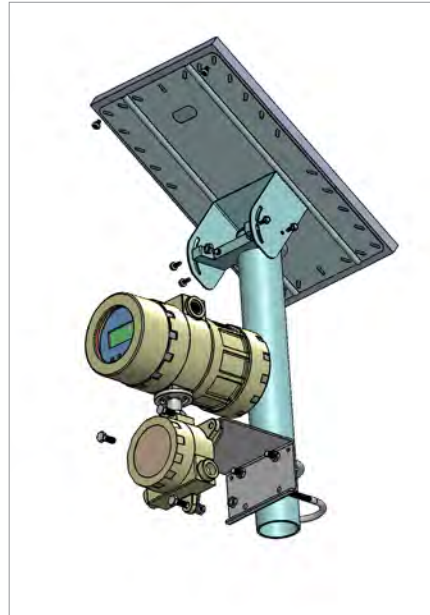


fig_7_2

- Select the ideal inclination depending on the installation and fix the screws.
- The system is designed so as to have the display on the side opposite to solar radiation.



fig_7_3



fig_7_1

8. INSERTION METERS

8.1 INTRODUCTION

The electromagnetic insertion meter MUT1222 was designed for measuring water's velocity.

The meter can be installed in any pipe of internal diameter between DN40 and DN1000.

The MUT1222 is designed for use in survey applications such as leakage monitoring and network analysis, and in permanent locations where cost or space limitations preclude the use of conventional full bore flowmeters.

NOTE

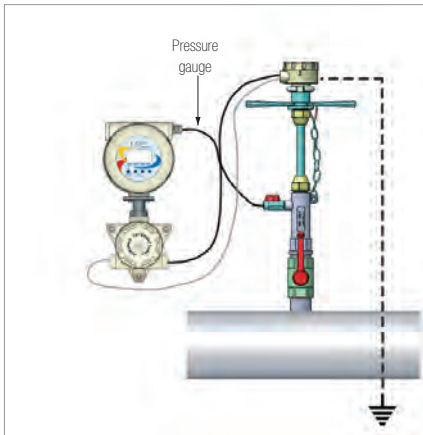
CARE OF THE EQUIPMENT:

- THE TIP OF THE MUT1222 IS A PRECISION-BUILT PART OF THE EQUIPMENT AND MUST BE HANDLED WITH CARE
- WHEN REMOVING/INSERTING THE PROBE INTO THE PIPE LINE, ENSURE THAT THE VALVE IS FULLY OPEN, TO AVOID ANY DAMAGE TO THE TIP AND OR THE BODY OF THE UNIT DAMAGE TO THE PROBE MAY COMPROMISE THE FLOWMETER AND ITS PERFORMANCES
- ANY PHYSICAL DAMAGE TO THE PROBE OF THE FLOWMETER INVALIDATES THE WARRANTY

8.1.1 FEATURES AND BENEFITS

- "Hot Tap" capacity
 - The MUT1222 can be installed quickly, easily and conveniently without interrupting the water flow in the pipe. The ball valve supplied enables the meter to be inserted through a hot tap assembly under full working pressure conditions, without major excavations, dewatering line, pipeline shutdown and cutting normally required for in-line metering.
- Ease of operation
 - Fittings to existing guidelines of 1" without the need for the major, expensive and time-consuming excavations associated with full bore meters.
 - The power options of battery (MC608B) and renewable energy (MC608R solar panel equipped) supplies, mean MUT1222 is easy to install and completely independent also in the most remote environments
- Integration of pressure and temperature measurement
 - In combination with MC608 converters and the integrated pressure/temperature measurement modules allows full control and measurement of the most important information in leakage control systems and in any other water monitoring and check point.
 - All data can be downloaded through the software MC608, made available as standard.

8.1.2 SYSTEM DIAGRAM

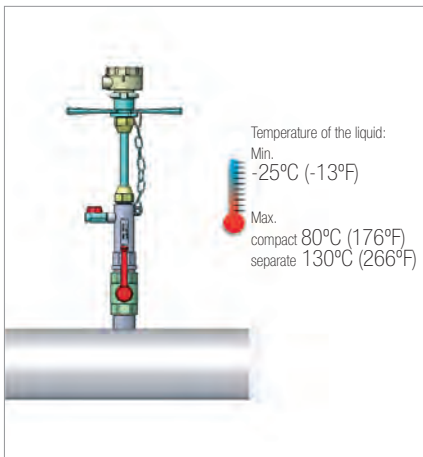


fig_812

8.1.3 MECHANICAL INSTALLATION

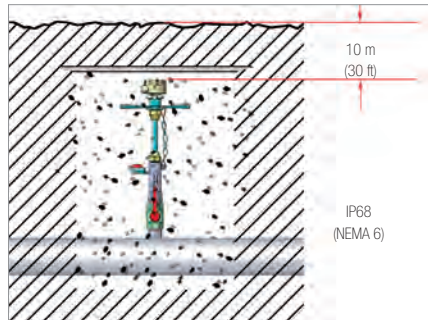
- Localization - installation and environmental conditions.

- Within the temperature limits



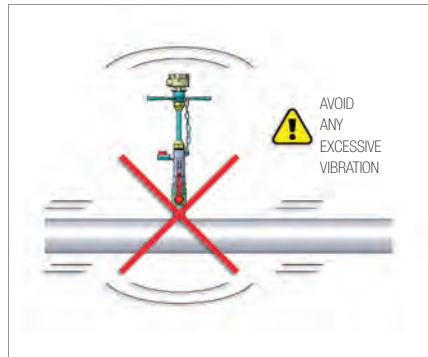
fig_813_1

- Within environmental limits



fig_813_2

- Avoid excessive vibration



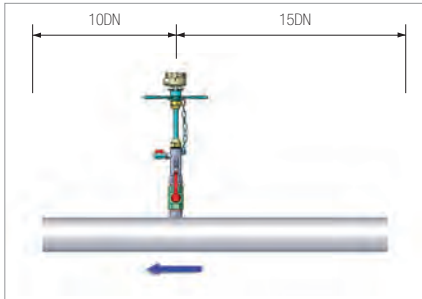
fig_813_4

- Localization - flow conditions

The probe must be installed at the mean axial velocity point, which is located at 1/8 of the internal diameter of the pipe.

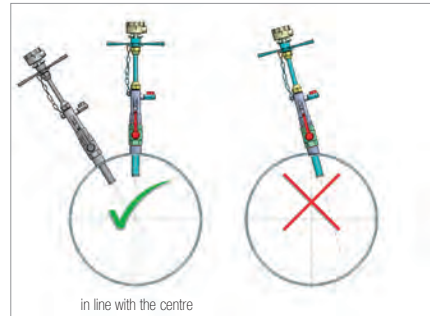
NOTE

MAKE SURE THE SENSOR IS INSTALLED IN THE PIPE WITH THE FLOW DIRECTION ARROW ON THE HANDLES, IN THE DIRECTION CORRESPONDING TO THE FLOW.



fig_813_5

Orientation



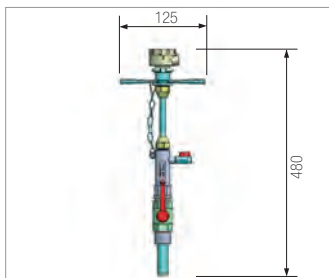
fig_813_7

NOTE

THE PIPE MUST BE ALWAYS FULL

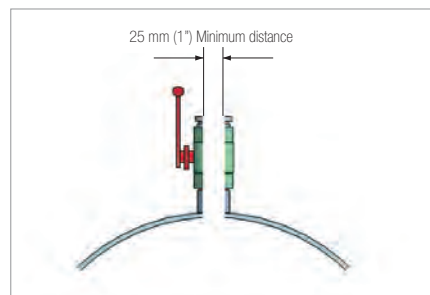


- Localization - Mechanics
- Overall dimensions



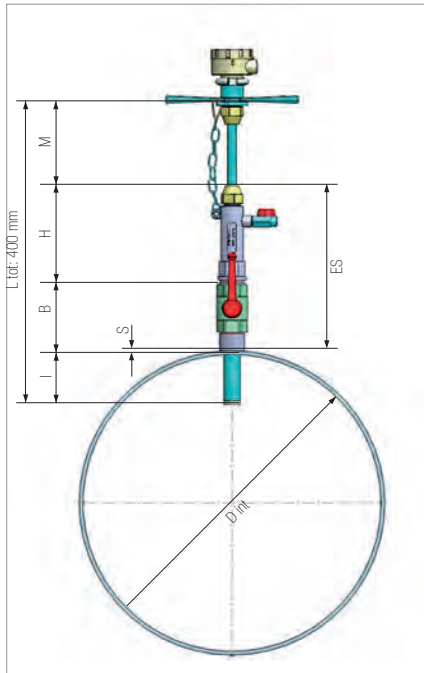
fig_813_6.tif

8.2 INSTALLATION



fig_821_1

8.2.1 MEAN AXIAL VELOCITY POINT (1/8 inside diameter)



fig_821_2

Legend:

D: Actual inner diameter

S: thickness of the pipe

B: Fixed distance

H: Body constant size (140mm)

I: insertion depth (Dint / 8)

M: Check for the measurement of insertion

ES: Euromag original parts standard size (225mm)

L: total size of the device (400mm)

$M = L_{tot} - ES - S - (D_{int}/8)$

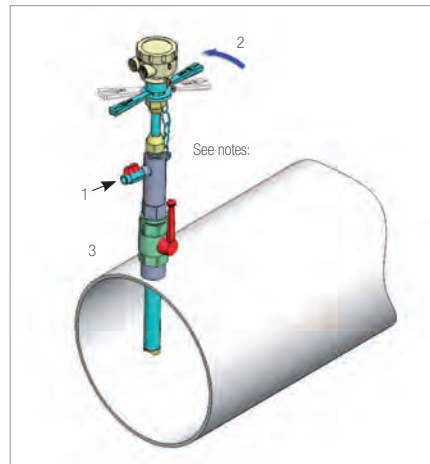
$M = 175 - S - D_{int}/8$

Example: D = 200mm, S = 3mm

$$M = 175 - 25 - 3 = 147$$

8.2.2 ALIGNMENTS

Align the indication arrow on the handles of the sensor with the flow direction



fig_821_3

Legend:

1. Loosen the screw

2. Align parallel to the pipe (within 2°)

3. Tighten to 40Nm (30 ft lbf)

8.2.3 Programming

Program the electronics with the right value of diameter (see section 10.3.2 Diameter setup).

9. CONVERTER MC 608

9.1 INSTALLATION

9.1.1 IDENTIFYING DATA PLATE

The data plate located on the converter displays the following information:

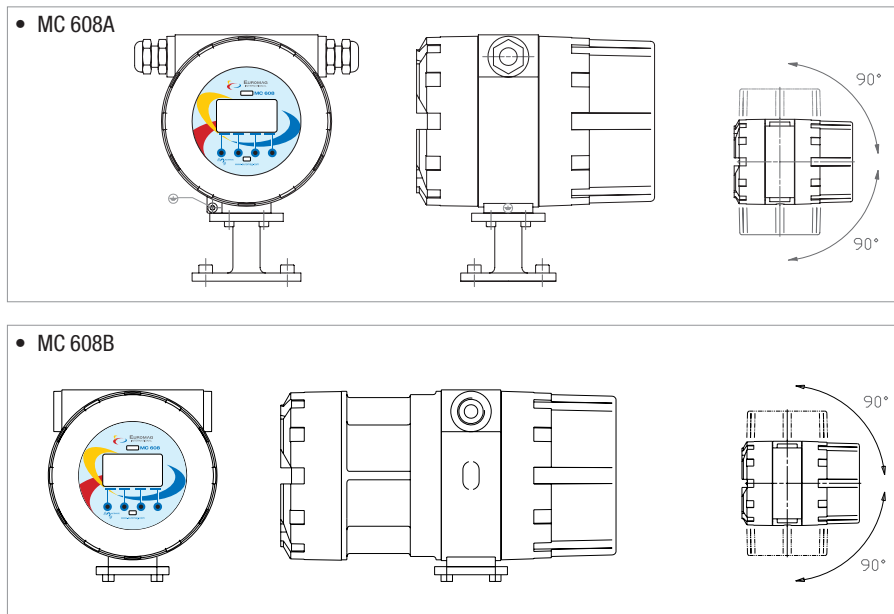
EUROMAG INTERNATIONAL		Made in Italy		CE
MODEL	MC 608	IP	68	
PART N°	WAP 320	Temp.	-20/+60°C	
POWER S.	90-264 V	Hz	50/60	
COUPLING	WAC 279			
OPTIONAL				

fig_9_1

- MODEL: converter model
- IP: degree of protection of the converter
- Part No.: serial number identifying the device
- Temp.: minimum/maximum temperature of working conditions
- POWER SUPPLY: supply voltage or battery powered (MC608B)
- HZ: frequency of supply voltage
- COUPLING: serial number identifying the sensor coupled to the converter
- OPTIONAL: other modules may be added

9.1.2 COMPACT VERSION

Figure 55 represents the converter MC 608 in the compact layout.




When the converter is purchased in compact version all the electrical connections are already performed by the manufacturer.

Before running the converter, proceed connecting the required outputs. For safety reasons, the power supply must be wired only after connecting the outputs.


The converter can be rotated to a 90° angle by loosening the bolts on the lower part of the converter attached to the sensor neck.

Once the new position of the converter is secured, carefully tight the bolts to secure the converter to the sensor.

 CAUTION!
WHILE TURNING THE CONVERTER POSITION, DO NOT PULL THE CABLES COMING FROM THE SENSOR.

Avoid strong vibrations on the converter, use the remote version in case vibrations may occur.

9.1.3 REMOTE VERSION

 CAUTION!
ONLY SKILLED TECHNICAL STAFF MAY HAVE ACCESS TO THE JUNCTION BOX

Cables coming from the sensor should be connected on the junction box located below the converter.

NOTE
THE CABLES ARE SUPPLIED ONLY WITH REMOTE VERSIONS

The MC608 converter may be either wall mounted or installed on a pole, using the tools supplied with the remote version as shown in the figure.

The COUPLING value in the converter nameplate shows the part number of the sensor to be connected.

Such information is shown on the converter too, please see Menu -> Other -> System info. The same info can be downloaded through the MC608 software using your lap top.

To ensure smooth functioning, always use the signal cables included in the delivery by the manufacturer.

NOTE

THE USE OF CABLES NOT PROVIDED OR CERTIFIED BY EUROMAG INTERNATIONAL MAY AFFECT THE CORRECT WORKING CONDITIONS OF THE SYSTEM AND CAUSE THE WARRANTY VOIDANCE.

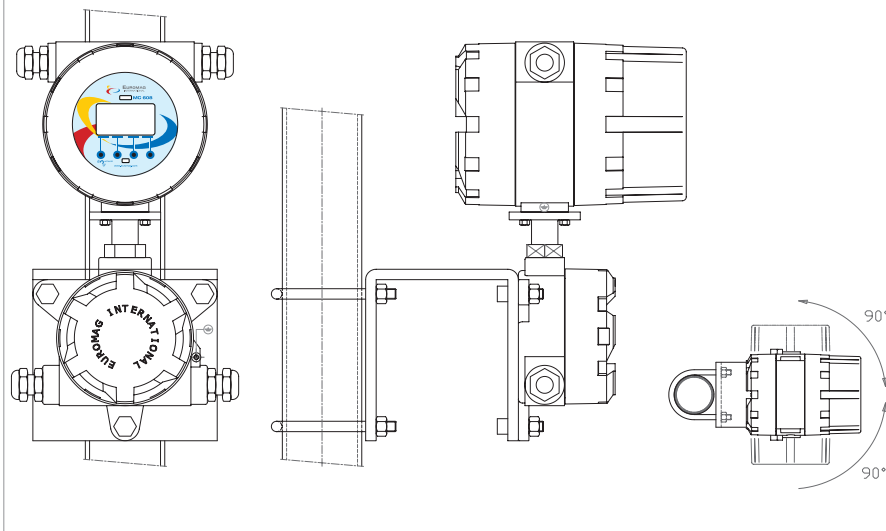


CAUTION!

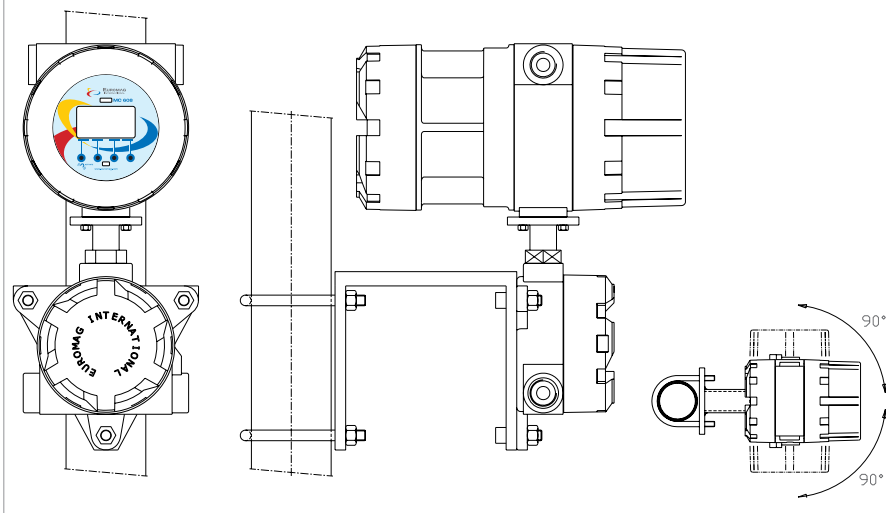
ALL THE OPERATIONS ON ELECTRICAL CONNECTIONS MAY BE MADE ONLY WHEN THE POWER SUPPLY IS CUT AND THE JUNCTION BOX OF THE CONVERTER IS CAREFULLY CLOSED. TAKE NOTE OF THE VOLTAGE DATA ON THE NAMEPLATE!

Separate version

- MC 608A



- MC 608B

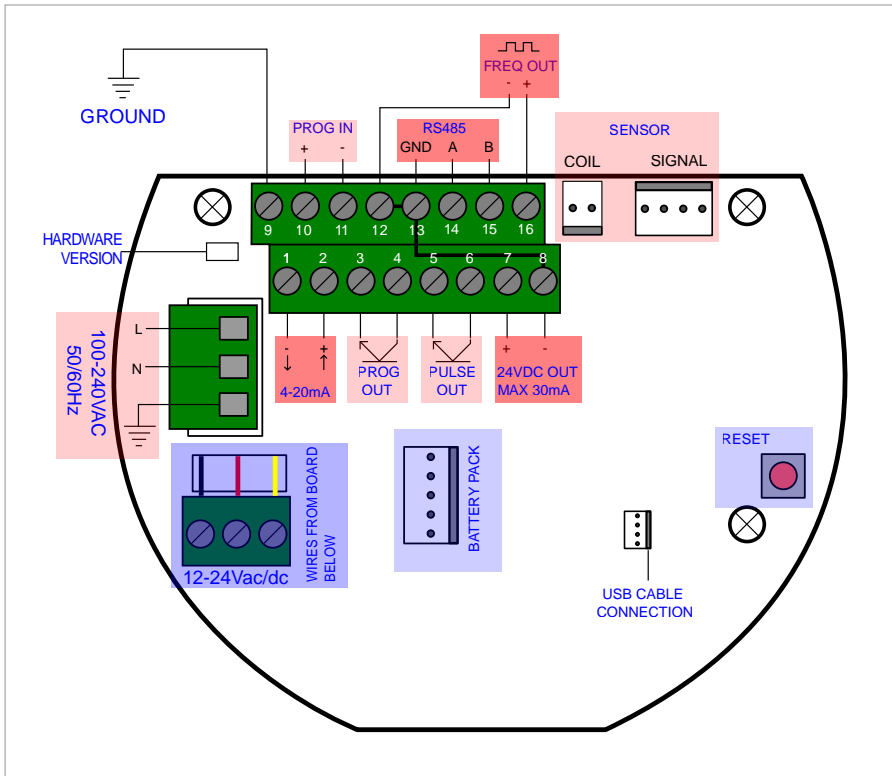


9.1.4 ELECTRICAL CONNECTIONS

⚠ CAUTION!

ANY WORK DONE ON THE ELECTRICAL JUNCTION BOX OR ELECTRICAL COMPONENTS OF THE DEVICE MUST BE CARRIED OUT BY PROPERLY TRAINED AND SPECIALIZED STAFF

MC608 ELECTRICAL DIAGRAM



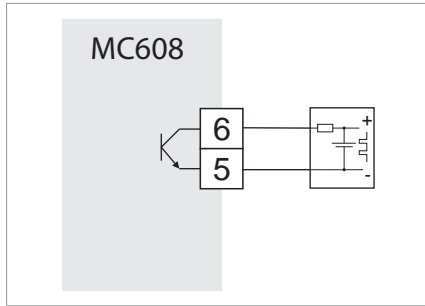
fig_914_1

PULSE OUTPUT

Clean contact (MC608A/B/R)

The device connected (PLC/external pulse meter) supplies its digital input with the required voltage to detect the pulses. The MC608 acts as a digital switch.

(Maximum voltage: 30Vdc, 50mA maximum current)

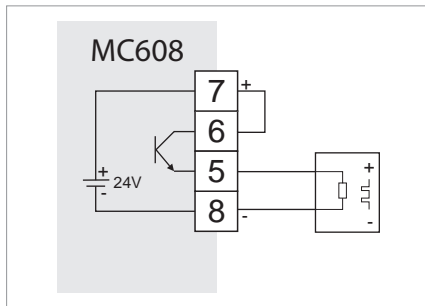


fig_914_2

Active 24V self-powered (MC608 from version 6-3)

The device connected (PLC/external pulse meter) is a passive digital input that accepts a 24V voltage level. IT SHOULD NOT

provide ANY additional voltage. The internal power supply 24Vdc is used to provide the necessary voltage. (Voltage 24V, maximum current 30mA*)

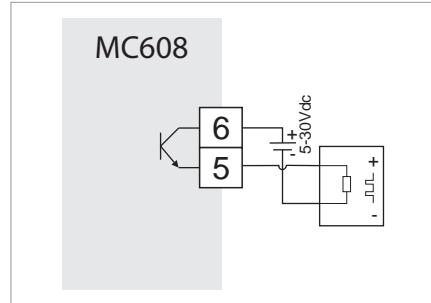


fig_914_3

Active 5-30V (MC608A/B/R)

The device connected (PLC/external pulse meter) is a passive digital input that accepts the voltage supplied to it by the external supply system used.

(Voltage 5-30V, maximum current 50mA)



fig_914_4

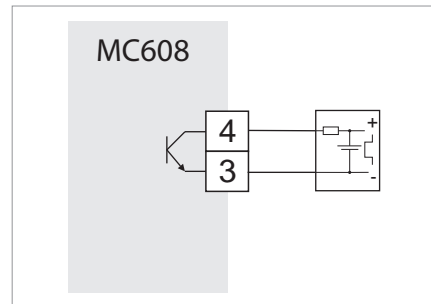
PROGRAMMABLE OUTPUT

Clean contact (MC608A/B/R)

The device connected provides its digital input with the required voltage to detect the logic level.

The MC608 acts as a digital switch.

(Maximum voltage: 30Vdc, 50mA maximum current)

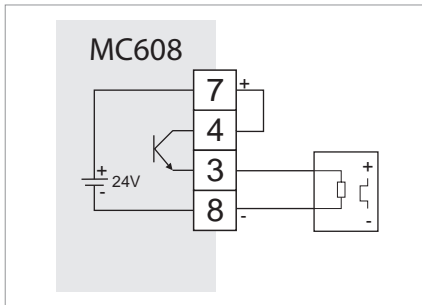


fig_914_5

Active 24V self-powered (MC608 from version 6-3)

The device is connected to a passive input that accepts a digital voltage equal to 24V. IT MUST NOT provide ANY additional voltage.

The internal power supply 24Vdc is used to provide the necessary voltage. (Voltage 24V, maximum current 30mA*)

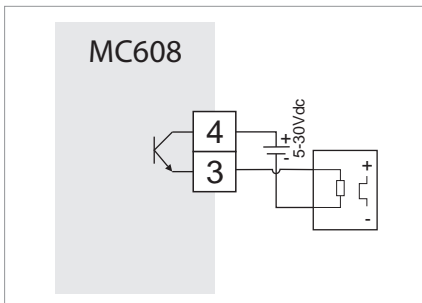


fig_914_6

Active 5-30V (MC608A/B/R)

The connected device is a passive digital input that accept the voltage level provided by the external power supply.

(Voltage 5-30V, maximum current 50mA)



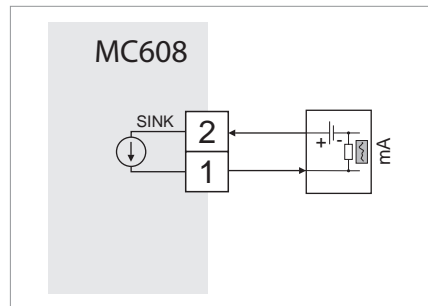
fig_914_7

4...20mA OUTPUT

Loop Powered

The connected 4-20mA receiver is a loop-powered model, powering itself the current loop.

(24VDC loop voltage of 24Vdc, maximum impedance 800 ohm)

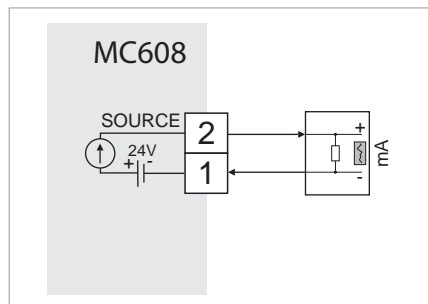


fig_914_8

Active (MC608 version 6-1 and 6-2)

The connected 4-20mA receiver is a passive milliamp-meter; the internal MC608 24Vdc power supply is internally connected.

(24VDC loop voltage of 24Vdc, maximum impedance 800 ohm)

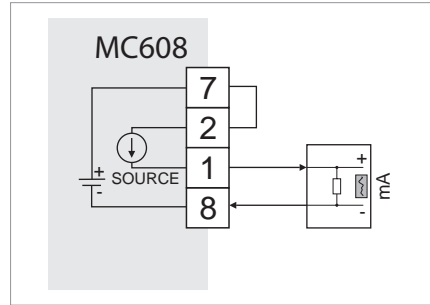


fig_914_9

Active (MC608 version 6.3 and subsequent)

The connected 4-20mA receiver is a passive milliamp-meter; the internal MC608 24Vdc power supply must be connected as shown.

(24VDC loop voltage of 24Vdc, maximum impedance 800 ohm)



fig_914_10

NOTE

CONNECT ONLY ONE OUTPUT AT A TIME WITH INTERNAL POWER SUPPLY
(7-8) AUX MAX 30 MA

9.1.5 RS485 MODBUS Output

The standard RS485 interface is available between terminals 13 - 14 -15 as shown in fig_914_1.

NOTE

THE RS485 OUTPUT IS A MODBUS STANDARD COMMUNICATION PORT, COMPATIBLE WITH ANY SOFTWARE THAT IS ABLE TO COMMUNICATE IN MODBUS, FOR MORE INFORMATION PLEASE REFER TO THE MODBUS MANUAL.

9.1.6 ELECTRICAL GROUNDING OF THE CONVERTER CASE

The MC608 case should be grounded. This connection should be carried out by grounding the bolt located in the lower part of the converter.

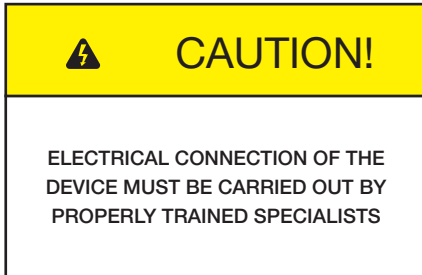
NOTE

MAKING A PROPER CONNECTION IS NECESSARY FOR AN EFFICIENT OPERATION OF THE DEVICE.

NOTE

MC608B OR MC608R CONVERTERS ARE EQUIPPED WITH PULSE OUTPUT AND THE 4..20mA OUTPUT ONLY IN LOOP MODE

9.1.7 CONNECTION TO THE POWER SUPPLY



Make sure all electrical connections are correctly performed before connecting the unit to the power supply. Check the power voltage on the name plate.

The unit may be supplied with voltage:

MC608A

90 ... 264 Vac

0 12 ... 24 Vac/dc

MC608B

Powered by lithium battery

0 12 ... 24 Vac/dc

MC608R

Powered by a rechargeable lithium battery

0 12 ... 24 Vac/dc

Power supply and battery charging is supplied by the solar panel

9.2 PROGRAMMING THE MC608 CONVERTER

MC608 configuration can be performed in different ways:

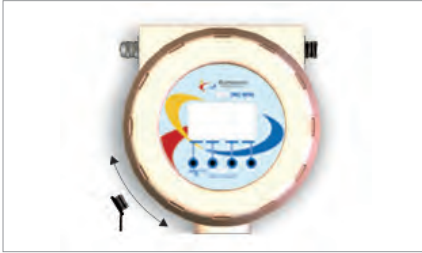
- Through the 4 push buttons located on the front display of the converter, unscrewing the front panel glass
- Via PC through the RS485 MODBUS output (see electrical connections) and the configuration software program Euromag MC608. The USB cable adapter is available at the manufacturer's on request.
- From the PC via the infra-red port located on the front of the converter, above the display and the Euromag software configuration program MC608

The Euromag MC608 software can be downloaded via www.euromag.com visiting the download area, or it can be ordered on CD.

Activation of the MC608B or MC608R in battery mode

Normal operation of the MC608B is "sleep mode". This mode preserves battery life while ensuring the functional operation of the product.

To recall the unit for next programming or value reading on the display, use the supplied magnetic swipe and slide it vertically on the front panel of the converter, suitably marked: "activate"



fig_92_1

MC608 configuration is made via PC using the Euromag MC608 software program.

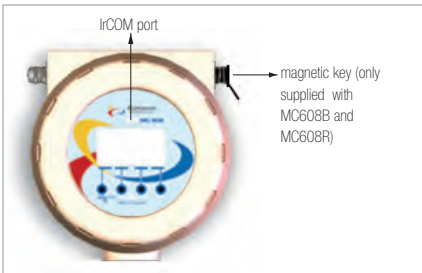
- Use an USB adapter for direct communication to PC (available at the manufacturer on request) or an infra-red interface unit.

MC608B or MC608R:

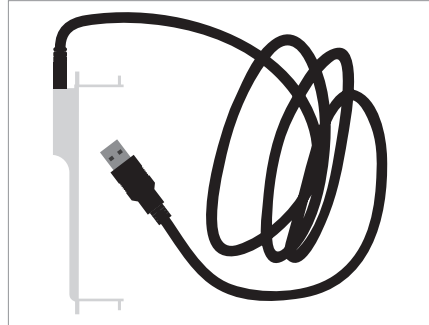
- Install the MC608 software on the PC, start the program, connect the unit to the PC and activate it with the magnet sliding it laterally on the front, at the “activate”. Select RS485 or infra-red communications, and press the CONNECT button (see below the screen of the MC608 program).

MC608A:

- Install the MC608 software on the PC, start the program and connect the unit to the PC. Select RS485 or infra-red communications and press the CONNECT button (see below the screen of the MC608 program).

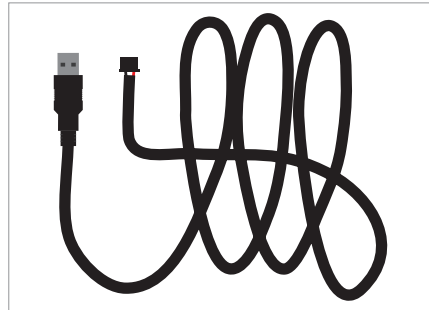


fig_92_2



fig_92_3

IrCOM cable



fig_92_4

USB - MODBUS cable

⚠ WARNING

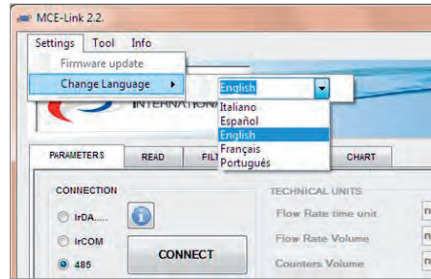
YOU MAY NEED TO CHANGE THE INPUT COM. TURN THE COM PORT COMMAND OF THE SOFTWARE TO SELECT THE CORRECT INPUT. NORMALLY IT IS THE COM WITH THE HIGHEST NUMBER.

Select infra-red or 485 or IrCOM communication for the main page of the software (view f.58).

NOTE

THE IRDA COMMUNICATION IS AVAILABLE ONLY ON MC608_5 AND MC608_6_1 CONVERTERS.

Select the language of the software



fig_92_5



fig_92_6

CONVERTER PASSWORDS:

The converter was built with three different levels of protection. Passwords can be modified.

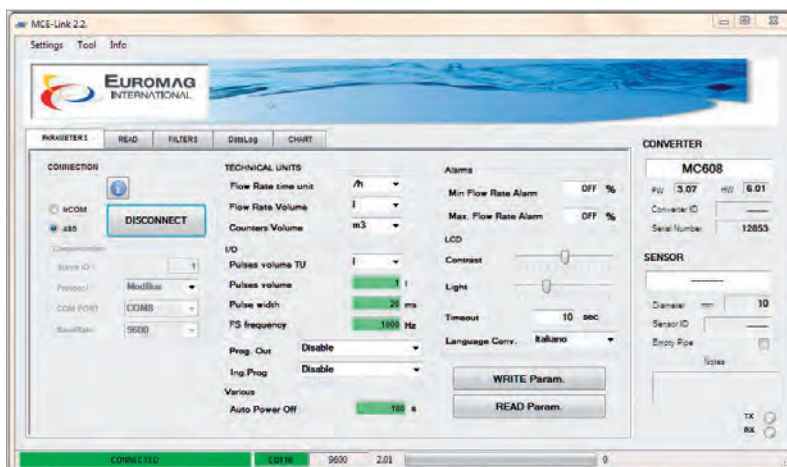
I level: 608111

II level: 709222

III level: 231042

To change passwords see the menu “memory” - password setup.

MC608 with correct connection: Parameters can now be read and changed.



fig_92_7

9.2.1 PROGRAMMING

To access the menu from the converter, simply press on the relevant button below the function.

Enter the Menu by pressing the Menu button.

MENU

- Options
- Counters
- Parameters
- I/O
- Other
- Memory

Follow the below chart for an overview of the available functions.

OPTIONS

Technical units

- Flow rate units
- Flow rate time base.
- Counters module
- Pulses unit
- Specific weight
- Temperature unit

Measurement frequency

- Measuring time

Display

- LCD backlight lev
- Backlight off
- LCD contrast

View options

- Last row

Full scale flow

Language

COUNTERS

T+

P+ (set zero)

T-

P- (set zero)

PARAMETERS

Ka setup

Diameter Setup

Filters setup

- Flow cut off
- Damping
- Bypass
- Peak cut

- Measure average

Line frequency

Zero calibration

Flow rate alarms

- MAX flow th.
- MIN flow th.

Empty Pipe th.

I/O

Pulses OUT

- Pulse quantity
- Pulses time ON
- Reverse flow rate
- Pulses out enable

Frequency output

- Full scale freq.
- Frequency output enable

Program. output

- Enabled/disabled
- Reverse Flow
- MAX flow th.
- MIN flow th.
- MAX/MIN flow th.
- Batching
- Excitation failure
- Empty Pipe

Program. input

- Enabled/disabled
- Zeroing p+
- Zeroing p-
- Zeroing p+/p-

Batching

Progr. output logics

OTHERS

System info

Time/Date

Reserved

Graph

Simulation

Communications

- Baud rate RS485
- MODBUS address
- Data connection

MEMORY

Load user copy

Save user copy

Factory settings

Data logger

- Show last row
- Full erase
- LOG range

Password setup

NOTE

ALL PROGRAMMING CAN BE DONE EITHER ON THE CONVERTER THROUGH THE PUSH BUTTONS, OR USING THE EUROMAG MC608 SOFTWARE PROGRAM

DATA TO BE DISPLAYED

The display is divided into 3 main areas.

The top area shows the symbols for status information, together with the indication on the duration of the battery (MC608B and MC608R)

power indication (MC608A) or indication on battery

supply and charging (MC608R), as well as the alarm symbols and instantaneous reading

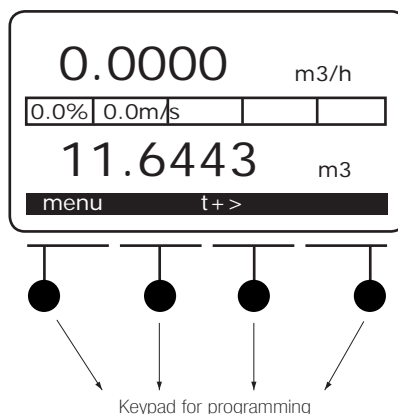
of the flow rate.

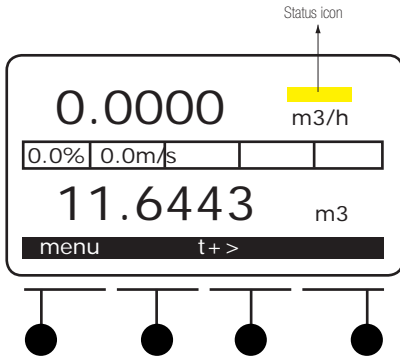
The central area shows a linear graph of the flow rate shown in percentage on the full scale flow rate.

The are at the bottom can be selected by the customer, and the possible options are:




- T+ total positive counter
- P+ partial positive counter
- T- total negative counter
- P- partial negative counter
- Date and time, temperature or pressure display (the latter available with optional module)

To select the required value simply click on the button corresponding to the arrow and make your selection, or select Menu -> Options -> view options -> Last row














STATUS ICONS / POWER SUPPLY

-  power supply
-  power batteries (remaining)
-  charging batteries (rechargeable version)

ALARM ICONS

-  flow rate > MAX threshold
-  flow rate < MIN threshold
-  excitation failure
-  measurement error
-  empty pipe alarm
-  alarm for pulses accumulation
-  board temperature alarm (with unit set)
-  low voltage alarm
-  full data logger alarm

COMMUNICATION STATUS

-  Data connection in progress

10. MENU DESCRIPTION

10.1 OPTIONS

Technical units

- Flow rate units
- Flow rate time base.
- Counters unit
- Pulses unit
- Specific weight
- Temper. unit

Measurement frequency

- Measuring time

Display

- LCD backlight level
- Backlight off
- LCD contrast

View options

- Last row

Full scale flow rate

Language

10.1.1 TECHNICAL UNITS

- Flow rate units

Select the volume technical unit for the instant flow rate

- Flow rate time base.

Select the time base for the instant flow rate

- Counters unit

Select the volume technical unit for the counters

- Pulses unit

Select the volume unit for the pulses

- Specific weight

You can enter the specific gweight of the liquid used


- Temperature Unit

Change the desired temperature unit

10.1.2 MEASUREMENT FREQUENCY

- Measuring time


Select the measurement time of the system between 10/15/30/45/60/120/180/240/300/360/420/48 seconds when battery powered mode is set (MC608B or MC608R).

 CAUTION!
FACTORY SETTING IS 45 SECONDS. ANY REDUCTION OF THIS FACTOR WILL AFFECT BATTERY LIFE WHEN USING MC608B IN BATTERY POWERED MODE

10.1.3 DISPLAY


- *LCD backlight level*

Increase or decrease backlit level

 CAUTION!
ANY INCREASE OF THIS FACTOR WILL AFFECT BATTERY LIFE WHEN USING MC608B OR MC608R

- *backlight OFF*

Increase or decrease shut off time of the display backlit

 CAUTION!
ANY REDUCTION OF THIS FACTOR WILL AFFECT BATTERY LIFE WHEN USING MC608B OR MC608R

- LCD contrast

Modify the contrast value of the display

10.1.4 VIEW OPTIONS

- *Last row*

Defines the display default information with the following options:

- T+ total positive counter
- P+ partial positive counter
- T- total negative counter
- P- partial negative counter
- Date time / Board temperature
- Process temperature/pressure (with optional module)

10.1.5 FULL SCALE FLOW RATE

Modify the full scale flow rate. The full scale flow rate standard is calculated according to a speed equal to 10 m/s.

UNIT	EQUIVALENTS
ml	1e-6 m ³
cl	1e-5 m ³
l	0.001 m ³
dal	0.01 m ³
hl	0.1 m ³
KL	1 m ³
ML	1,000 m ³
in3, cubic inches	1,63871e-5 m ³
oz US, US fluid ounce	0,02957 m ³
gal US, US gallons	3,78541 m ³
ft3, cubic feet	28,31685 m ³
bbl oil, oil barrel	158,984 m ³
g	0,001 Kg
hg	0,1 Kg
kg	1 Kg
q	100 Kg
t	1000 Kg
lb, pounds	0,45359 Kg

10.1.6 LANGUAGE

Select the language of the menu between:

- ENGLISH
- ITALIANO
- ESPAÑOL
- PORTUGUÊS
- FRANÇAIS

10.2 COUNTERS

- T+
- P+ (set zero)
- T-
- P- (set zero)

There are four different counters with the converter MC608, two positive and two negative.

Only partial counters can be set to zero.

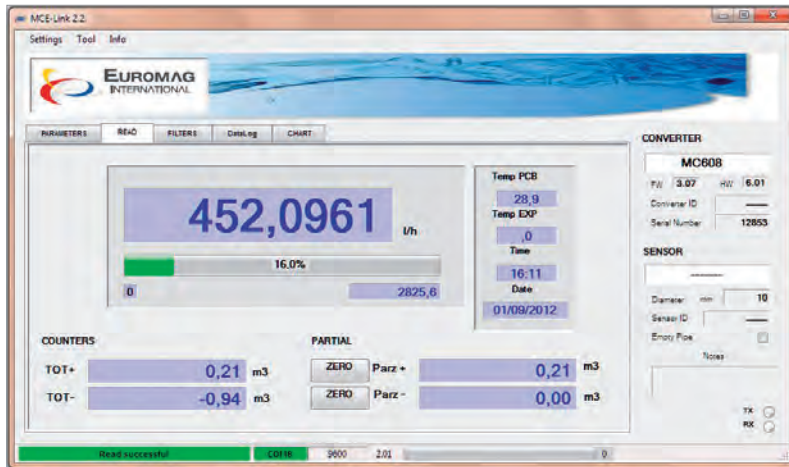
To set the counters to zero from the MC608 software program, move to the READ screen - see the picture shown below.

Only partial counters can be set to zero.

The same screen also displays a linear bar that shows the percentage of the instantaneous flow rate in relation to the full scale flow rate set in the converter, which is shown in the graph below.

The same screen shows the internal temperature of the converter (Temp PCB, date and time).

External temperature or system operating pressure with optional add-on modules(s) and sensors



fig_10_2

10.3 PARAMETERS

Ka setup

Diameter Setup

Filters setup

- Flow cut off
- Damping
- Bypass
- Peak cut off
- Measure average
- Line frequency

Zero finder

Flow rate alarms

- MAX flow th.
- MIN flow th.
- Empty pipe th.

Empty Pipe th.

10.3.1 KA CHANGE

It allows to modify the KA calibration factor.

CAUTION!

ONLY AUTHORIZED PERSONS CAN
MODIFY THE KA FACTOR. THE KA
FACTOR MUST BE EQUAL TO THE
SENSOR COUPLED;
CHECK ON THE RATING PLATE OF THE
FLOW METER

10.3.2 DIAMETER CHANGE

Allow changing the diameter. In case of insertion flow meter, please enter the actual real inner diameter value of the pipe in this menu.

10.3.3 FILTERS SETUP

NOTE

FILTERS SHOULD BE ADJUSTED ONLY IF STRICTLY NECESSARY. FACTORY SETTINGS ARE ALREADY CALIBRATED FOR A CORRECT WORKING CONDITION.

- Flow cut off

In this sub-menu you will find a value expressed as a percentage of full scale: if the actual flow rate is less than this value, the device will show a flow equal to 0.

NOTE

SHOULD YOU NEED TO REDUCE THE FLOW CUT OFF FILTER, IT MEANS THE SPEED OF THE LIQUID IS LOWER THAN THAT RECOMMENDED ONE FOR A GOOD MEASUREMENT.

- Damping

Increase the stability of the reading by adding a higher average of the displayed values.

To increase the stability, increase the value in this sub menu.

- Bypass

A percentage value that represents a threshold on which the digital filter is NOT calculated.

For example:

In case where a value of 50% is entered

- IF the flow rate varies by 50% more than the previous value
- THEN the flow rate shown will take on an actual value
- OTHERWISE the digital filter will be applied, that is to say that the shown flow rate will slowly reach the actual value

- Peak cut off

In this sub-menu you will find a value expressed as percentage of the full scale. If the measurement of the flow rate shows amplitude peaks > of the set value, these will not be taken into account in the measurement. For example, setting the value to 10%, a peak > 10% of full scale will be ignored by the device

- Measure average

Increase the stability of the reading by enlarging the actual measurement filter.

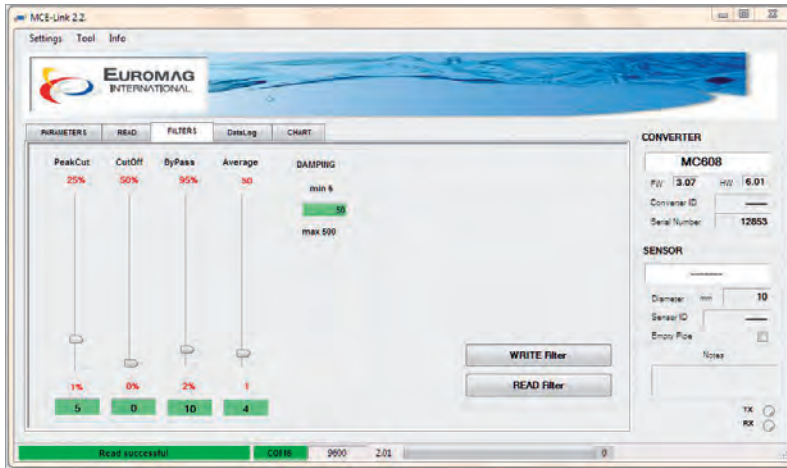
To increase the stability, increase the value in this sub-menu

- Line frequency

Set the frequency of the local power supply (50Hz or 60Hz) to minimize interference

To read and modify the filters value from the MC608 software program, move to the FILTERS screen - see the picture below

Modify the filters within the indicated range.



fig_1033_1

10.3.4 ZERO FINDER

This setting is used to perform the device zero calibration. Before performing the zero calibration, ensure that:

1. the sensor is full of liquid
2. the liquid is perfectly stationary
3. the sensor has correct electrical grounding

NOTE

THE MC608 HAS AN AUTOMATIC ZERO CALIBRATION FUNCTION. USE THE ZERO FINDER ONLY WHEN STRICTLY NECESSARY

10.3.5 FLOWRATE ALARMS

- MAX flow th.

Set the maximum value of flow rate in percentage on the full scale value. This value is factory disabled. Selectable range goes from +5% threshold to 100% of the full scale value. To disable the feature, select > 100%

- Min flow th.

Set the minimum value of flow rate in percentage on the full scale value. This value is factory disabled. Selectable range goes from 1% to maximum threshold of 95% of the full scale value.

NOTE

WHEN MAX OR MIN FLOW RATES ARE ENABLED, A SYMBOL WILL APPEAR ON THE DISPLAY IN CASE THESE VALUES WILL BE REACHED.

10.3.6 EMPTY PIPE THRESHOLD (Available with sensors having 4 electrodes)

Allows you to adjust the sensitivity of the empty pipe detection. Move the selection to the "E" if the empty pipe alarm does not appear, to "F" if the alarm does not disappear with the pipe full.

NOTE

TO TEST THE EMPTY PIPE DETECTION, PRESS THE "TEST" BUTTON

10.4 I/O

Pulses OUT

- Pulse quantity
- Pulses time ON
- Reverse flow rate
- Pulse output enable

Frequency output

- Full scale freq.
- Frequency output enable

Program. output

- Enabled/disabled
- Reverse Flow
- MAX flow th.
- Min flow th.
- MAX/MIN flow th.
- Batching
- Excitation failure
- Empty Pipe

Program. input

- Enabled/disabled
- Zeroing p+
- Zeroing p-
- Zeroing p+/p-

Batching

Progr. output logics

10.4.1 PULSE OUTPUT

- Pulse quantity

Select the volume of the pulses.



CAUTION!

WITH MC608B OR MC608R SELECT A VOLUME LARGE ENOUGH SO THAT DURING THE MAXIMUM FLOW OF THE PROCESS THE TIME INTERVAL BETWEEN TWO CONSECUTIVE PULSES IS GREATER THAN 1 SECOND IN ORDER TO PRESERVE THE BATTERY LIFE.

- MC608A (powered supply version)

NOTE

AVOID PULSES SATURATION, THIS MAY LEAD TO AN ACCUMULATION OF PULSES WHICH SHOULD NOT BE PROVIDED IN REAL TIME CONSIDERING THE ACTUAL FLOW RATE.

Calculation of the parameters (values must be re considered technical units of the converter)

[Vp=litres, Tp=seconds, Q=litres/seconds,

Qmax= system maximum flow]

$$Vp > Qmax * 2Tp$$

$$Tp < Vp / 2Qmax$$

- MC608B or MC608R battery powered**NOTE**

HIGH FREQUENCIES OF PULSES WILL
AFFECT BATTERY LIFE

Calculation of the parameters (values must be re considered according to the technical units of the converter)

[[Vp=litres, Tp=secons, Q=litres/seconds]

$$Vp > Q_{max} * 20 T_p$$

$$T_p < Vp / 20 Q_{max}$$

- Pulse time on

Select the ON time duration of the pulse on a range included between 1 and 1999 ms

**CAUTION!**

WITH MC608B SELECT AN ON TIME OF
NO MORE THAN 0.1 SECONDS (100MS)

- Reverse flow (off / on)

Acting on this function, in the case of negative flow, the pulses from the pulse output will be enable/ disabled

- Enable pulse output

Select to disable the frequency output and activate the pulse output (factory condition)

10.4.2 FREQUENCY OUTPUT

- Full scale freq.

Set the maximum frequency corresponding to the full scale flow rate value.

Selectable range: 100 Hz ... 10 KHz

- Enable freq. output

Select to disable the pulse output (which becomes PWM, pulse width modulation) and set the frequency output

10.4.3 PROGRAMMABLE OUTPUT

You can choose between one of the following options for the programmable output:

- Enabled/disabled
- Reverse Flow
- MAX flow th.
- Min flow th.
- MAX/MIN flow th.
- Batching
- Excitation failure
- Empty Pipe

10.4.4 PROGRAMMABLE INPUT

You can choose between one of the following options for the programmable input:

- Enabled/disabled
- Zeroing p+
- Zeroing p-
- Zeroing p+/p-

NOTE

IF THE PROGRAMMABLE OUTPUT IS SET TO "DOSAGE", THE PROGRAMMABLE INPUT WILL BE USED ITSELF AUTOMATICALLY DEPENDING ON DOSAGE, AND CANNOT BE CHANGED.

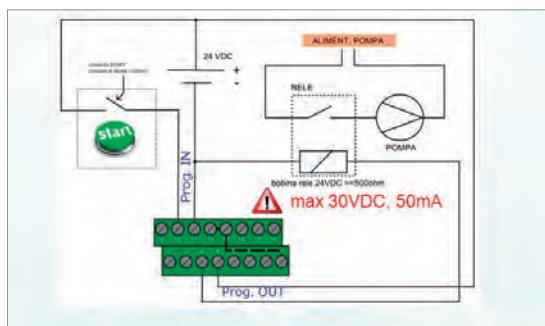
10.4.5 BATCHING

Set the volume to be dosed. Available only with MC608A

Example of connection to the programmable output

NOTE

TO ENSURE ADEQUATE PRECISION THE DURATION OF THE DOSAGE, WITH A FLOW REGIME, MUST BE GREATER THAN 60 SECONDS.



fig_1045_1

10.4.6 PROGRAMMABLE OUTPUT LOGICS

You can change the programmable output logics between NO/NC - normally open, normally closed.

In battery operated mode, the output is only NO.

10.5 OTHER

System info

Time/Date

Reserved

Graph

Simulation

Communications

- Baud rate RS485
- MODBUS address
- Data connection

10.5.1 SYSTEM INFO

Shows the system information. These values cannot be changed by the end user

10.5.2 TIME/DATE

Displays date, time, temperature of the motherboard, power supply voltage.

10.5.3 RESERVED

Menu under exclusive use of the manufacturer.

10.5.4 GRAPH

Shows the graph of the measured flow rate

10.5.5 SIMULATION

The MC608 has a built in flow simulator

that checks and adjusts the pulse output to any connected device system.

NOTE

WHEN USING THE FLOW SIMULATOR
THE COUNTERS WILL NOT DETECT
AN INCREASE IN THEIR VALUES

10.5.6 COMMUNICATION

- Baud rate RS485

Allows to adjust the RS485 baud rate on a range between 2400 and 115,700 bps.

- MODBUS address

Allows to adjust the address of the MODBUS communication between 1 and 255.

10.5.7 DATA CONNECTION (RS485/IRCOMM)

Allows you to select the RS485 port or infra-red port for connection to PC.

Before using infra-red communication, make sure you have enabled the converter to function IrCOMM:

Menu -> Other -> Communication -> Data Connection -> IrCOMM

10.6 MEMORY

Load user copy

Save user copy

Factory settings

Datalogger

- Show last row
- Full erase
- LOG interval

Password setting

10.6.1 LOAD USER COPY

Allows to load customized settings.

10.6.2 SAVE USER COPY

Allows to save customized settings.

10.6.3 LOAD FACTORY SETTINGS

Allows to load factory settings.

10.6.4 DATALOGGER

- Show last row

Shows last informations logged. Date, time, counter, instant flow rate, temperature, battery condition Others information stored (e.g. temperature, pressure process) are displayable only by downloading the data.

- Full erase

Erase memory of the converter.

- LOG interval

Select logging range.

1 minute minimum / maximum 120 minutes

WITH BATTERY POWERED MC608B AND MC608R PRIORITY IS GIVEN BY THE RANGE OF MEASUREMENT.

(ACQUISITION> = MEASUREMENT)

To read and change the memory data from the MC608 software program, move to the DATA LOG screen - see the picture below.

Select START and END row to read, the "get last log" button will reach the last available log.

Press the READ Log button to download the data.

Press "SAVE CSV" to save data on your PC in CSV format.

Press "Reset datalog" to completely reset the memory of the converter.

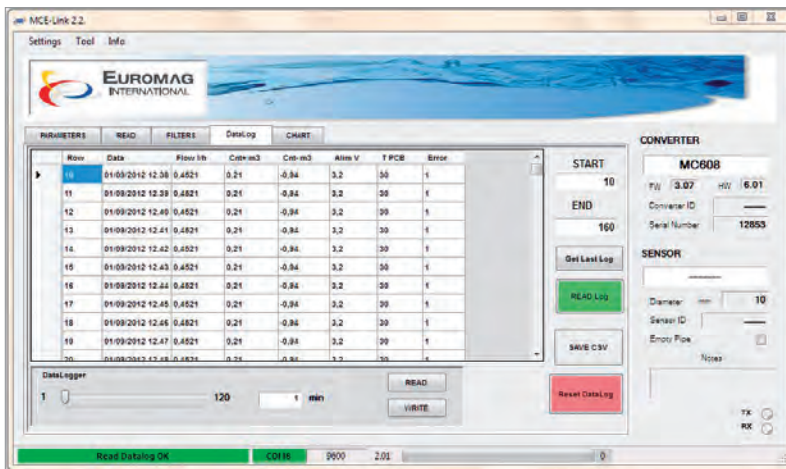


CAUTION!

BEFORE ERASING THE MEMORY,
MAKE SURE TO SAVE ALL DATA

NOTE

DATA LOGGING INTERVAL CAN BE
MODIFIED ON THE MAIN SCREEN, ON
A RANGE BETWEEN 1 MINUTE AND
120 MINUTES.



fig_1064_1

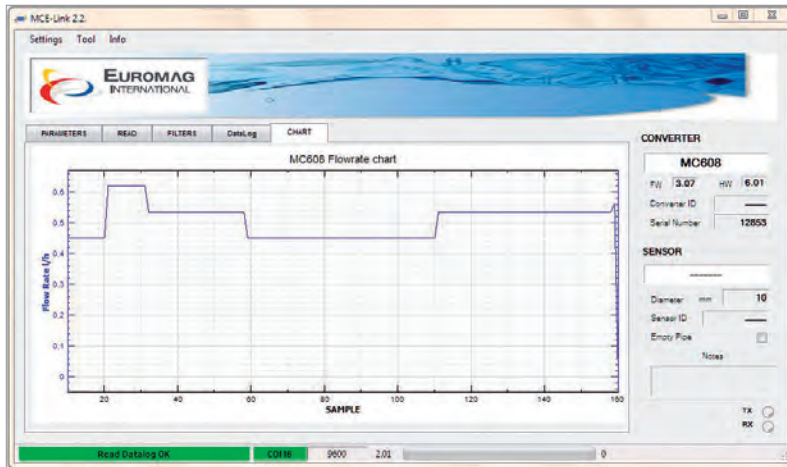
To view the last row acquired by the converter, select "Last log Settings". You will then see the last line number stored. Then select "download log" to display the history of the available data.

To save the data in a readable format with Excel, click on "save CSV".

To change the storage time of the data logger, click read, and then act on the horizontal scroll key between

1 and 120 minutes in order to change the storage time interval. Click on Write to program the converter with the new data and make the change effective.

After reading the data, moving to the GRAPH screen will also be available a flow rate chart, see the figure below.



fig_1064_2

10.6.5 PASSWORD SETTING

Allows you to change the 3 levels of password.

To access the selection of the 3 pwd to be changed (L1, L2, L3) the level 3 password is prompted.

11. TECHNICAL DATA

11.1 General features

Power	MC608A: 90...264 Vac 12/24 Vac/dc
	MC608B: On Battery Battery Life Expectancy T = 0/50°C (32/122°F) up to 10 years
	MC608R: With rechargeable battery + 10W solar panel
Display	Graphic LCD 128x64 pixels, display area 50x25mm, backlit with white light. Contents of the programmable display
Keyboard	Yes, 4 push buttons
Programming and communication	With push buttons
	Through IrCOM interface and laptop with dedicated software
	Through Modbus USB cable and laptop with dedicated software
	Communication RS485 Modbus RTU
	HART communication optional
	Optional communication with integrated GSM / GPRS module
Output signals	Analog output active / passive 4...20 mA
	AUX 24Vdc output 30mA max
	Digital output for up to 1000 Hz pulse duty cycle up to 50% for instant flow only positive positive negative
	Programmable digital output for: <ul style="list-style-type: none"> • Reverse Flow • MAX flow th. • Min flow th. • MAX/MIN flow th. • Dosage • excitation energy • stopped empty Pipe
	Digital outputs in active frequency 0-10 kHz
	All outputs are optically isolated. Digital outputs with a maximum capacity of 35V dc 30mA.
Fields of temperature	Ambient: -25 C° to 60 C°
	Storage: -30 C° to 70 C°
Signal cables	Euromag cables: <ul style="list-style-type: none"> • CA22 - cables for sensors with 4 electrodes • CA23 - cables for 2 or 3 electrode sensors
Consumption	MC608A: <ul style="list-style-type: none"> • Min 5W • Max 10W

Pressure sensor	PA21Y: 0...20 Bar; 1/8" GAS male, connector with fly coupling installed in factory; standard cable 5m long; code PRTR00001
Temperature sensor	PT500: CLASS A, 4-wire, -20C° to 180°C; 1/4" cockpit included, 50mm long, 6mm diameter; standard cable length 5m; code PRTR00002

11.2 Certificates and approvals

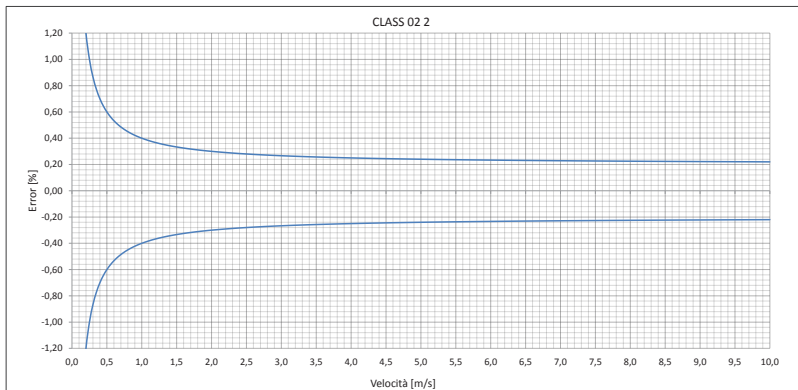
CE	This device fulfils the legal requirements of the EC directives. The manufacturer certifies successful testing of the product by applying the CE mark.
Electromagnetic Compatibility	Directive 2004/108/CE - EMC
	Harmonised standards EN 61326-1:2006; EN 55011:2009 + A12010; EN 6100-3 (2/3); EN 6100-4 (2/3/4/5/6/8/11)
Electrical Safety	Directive EN 61010-1 (pending)
IP degree	EN 60529 (in pending)
ATEX certificates	On sensor: II 2G Exmb IIC T4: <ul style="list-style-type: none"> • EN 60079-0 • IEC 60079-18
	On the converter: pending
Approvals for use in drinking water and food	WRAS
	Community legislation: <ul style="list-style-type: none"> • Reg. 1935/2004/CE • Reg. 1895/2005/CE • Reg. 10/2011/UE - 2023/2006/UE
	Italian legislation: <ul style="list-style-type: none"> • Decr. Min. 21/03/1973 • DPR 777/82
	USA Directive: <ul style="list-style-type: none"> • FDA, Food and Drug Association • USA regulations sections 177,1550 (a) (1) and (b)
International certificates:	SPAN Certificate. Ref. SPAN/PPI/300-10/665/B/W-1 – /S-1 Standard SIT / OIML R76 Water service industry Malaysia and Federal Territory of Labuan

11.3 Accuracy

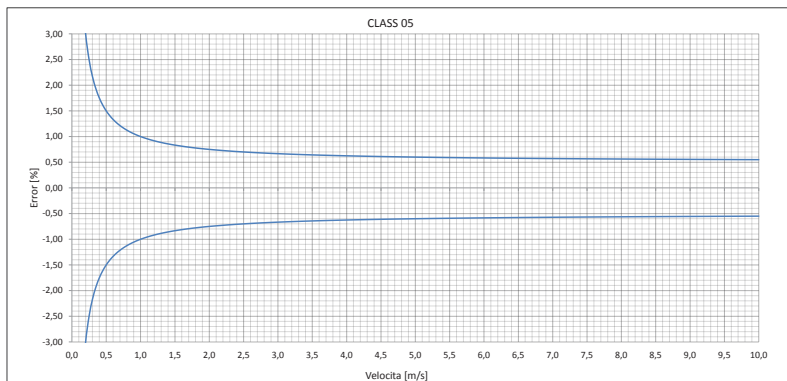
Reference condition:

- Measurement fluid: water
- Temperature: 20°C / 68°F
- Pressure: 1 bar / 14.5 psi
- Upstream diameters: ≥ 5 DN

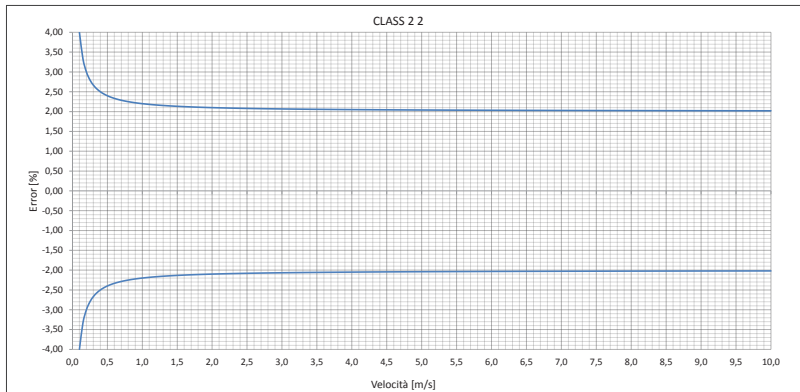
Model	Accuracy class	Accuracy	Graph
MC608A	Class 02 2	$\pm 0,2 \% \pm 2\text{mm/s}$	1
MC608B/R	Class 05 5	$\pm 0,5 \% \pm 5\text{mm/s}$	2
MC608A/B/R coupled to insertion flowmeters	Class 2 2	$\pm 2 \% \pm 2\text{mm/s}$	3



Graph 1



Graph 2



Graph 3

12. RETURNING A FLOWMETER FOR CHECK UP AND REPAIR

The device was carefully manufactured and has passed rigorous testing before leaving the factory. If correctly installed and maintained, the event of a malfunction should be highly unlikely.

Should you nevertheless need to return a device for inspection or repair, please pay strict

Attention to the following points:

- A result of the provisions of law on the environmental protection and the safeguarding of health and safety of our staff, the manufacturer may only handle, check and repair those devices returned without having being in contact with free-risks products for both the staff and the environment.
- This means that the manufacturer can carry out the service on the device only if the latter is accompanied by the following certificate

(See next section) attesting that the device itself can be handled safely.







13. APPENDIX - TROUBLESHOOTING

SYMPTOMS	POSSIBLE REMEDIES
The converter shows a flow rate even there is static or no flow	<ul style="list-style-type: none"> • There is air in the pipe, try to avoid the creation of bubbles selecting a more suitable position for the sensor (see installation paragraph). • Check that the sensor is full with liquid. • Electrical conductivity of the liquid is too low or is not compatible with the material used for the sensor electrodes. • Perform manual zero calibration if necessary (Menu - Parameters, sub-menu - zero calibration).
Flow reading is highly unstable.	<p>Possible causes are:</p> <p>1- HYDRAULIC Air bubbles or unstable flow (vortex motion). The minimum required linear distances upstream and downstream of the device were not complied with.</p> <p>2- ELECTRIC Grounding missing or done in an incorrectly way, oxidized nodes, very noisy ground point, usually in common with the grounding systems of pumps or inverters. Change the grounding point or preferably create a new one for the exclusive use of the meter.</p> <p>NOTE: If with full pipe and stable liquid an unstable reading can be observed (which varies rapidly) then most likely it is a problem of electrical noise</p> <p>Only if necessary, set the filters as follows:</p> <ul style="list-style-type: none"> • Set Damping to 150 • Reduce the peak cut filter • Increase the bypass filter
External pulse totalizer shows results different from the expected ones.	Test the output with the external flow simulator and the converter-pulse counter system, simulating a flow rate through System > Simulation.

The display is off and does not turn on.	There is no voltage supply, or the voltage supply is incorrect. Check the power supply voltage on the name plate of the converter. In case of MC608B check the battery life and replace the battery pack.
Liquid is flowing and the pipe is filled, but NO reading is available	Reduce the flow cut off filter (factory settings is 2% of the full scale) NOTE: Should you need to reduce the flow cut off filter, it means the speed of the liquid is lower than that recommended for an accurate measurement. It is advisable to lower the full scale (120% of the maximum of the process).

ALARM MESSAGES

POSSIBLE CAUSES AND SOLUTIONS

<p>Excitation failure</p> 	<ul style="list-style-type: none"> • Incorrect connections of cables • Sensor damaged. Damaged lining or electrodes. Possible infiltration of liquid inside the sensor • Converter damaged <p>It is recommended to perform a test on the sensor -> circuit between coils A - B: 50 - 250 Ohm</p> <p>Request the "sensor test" to the factory</p>
<p>Measurement error</p> 	<ul style="list-style-type: none"> • Empty Pipe • Air bubbles within the liquid • Incorrect electrical grounding <p>It is advisable to check for correct installation of the sensor in the three points indicated and carry out a test on the sensor -> with full pipe (A or B) - ground > 100 MOhm</p>
<p>Empty Pipe</p> 	<ul style="list-style-type: none"> • Empty pipe detection <p>This message is displayed with sensors that have 4 electrodes. Indicates the alarm of empty pipe, or even only partially empty. In case of persistent message with full pipe (more than a few minutes) act on the empty pipe threshold (see section 10.3.6 Empty pipe threshold).</p>
<p>Pulses accumulation</p> 	<ul style="list-style-type: none"> • Pulse frequency incorrect <p>It is advisable to change the volume settings and pulse duration. See the section for pulse output setting</p>
<p>Supply voltage</p> 	<ul style="list-style-type: none"> • Supply voltage out of operating range • Converter damaged <p>Check the power supply network</p>
<p>Data logger full</p> 	<ul style="list-style-type: none"> • Data logger memory full <p>It is advisable to download the data to PC, and erase the memory of the converter</p>

REPAIR APPLICATION FORM

Company Name _____

Company address _____

Phone _____ Fax. _____

Type of sensor / converter _____ Series No. _____

Type of liquid _____ Interior cleaning (Y / N) _____

Claim _____

We hereby confirm that there is no risk to persons or the environment due to any residual

substances contained in the device that is returned

Data _____

Company stamp _____ Signature _____



Euromag International SRL

Via Torino 3-35035 - Mestrino - PADOVA - ITALY

Tel. +39/049.9005064 - Fax. +39/049.9007764

euromag@euromag.com - www.euromag.com




TD 210-1-ITA